



# **KIP C7800 User Manual**

Thank you for purchasing the DIGITAL COLOR PRINTER KIP C7800.

This Hardware Operation Guide contains functional and operational explanations for the KIP c7800. Please read this Hardware Operation Guide carefully before using the Printer. Please keep this Hardware Operation Guide for future reference.

When this machine is installed in U.S.A.

This equipment satisfies the requirements in Part 15 of FCC Rules for a Class A computing device. Operation is subject to the following two conditions:

- (1) This device may not cause harmful interference.
- (2) This device must accept any interference received, including interference that may cause undesired operation.

When this machine is installed in Europe

This equipment satisfies the requirements in Pub.22 of CISPR Rules for a Classic A computing device.

Operation of this equipment in a residential area may cause unacceptable interference to radio and TV reception requiring the operator to take whatever steps are necessary to correct the interference.

**Do not install this machine around electronic equipment or precision instruments. Other devices may be affected by electrical noise during operation.**

**If Machine is installed near other electronic equipment, such as a TV or a radio, interference to said equipment, such as noise or flickering, may occur.**

**Use a separate power line and install the PRINTER as far as possible from said equipment.**

The symbol shown indicates that this product conforms to Directive 2002/96/EC of the European Parliament and the council of 27 January 2003 on waste electrical and electronic equipment (WEEE) and does not apply to countries outside of EU.



Only For EU Member States

The symbol shown indicates that this product conforms to SJ/T11364-2006 of People's Republic of China Electronic Industry Standard and does not apply to countries outside of People's Republic of China.



The symbol shown indicates that this product conforms to GB 18455-2001 11364-2006 of National Standard of the People's Republic of China and does not apply to countries outside of People's Republic of China.



## Safety Warning

The following warnings are very important in order to safely use this product. These notes are important in preventing danger to the operator or operation of the printer.

The following symbols are found throughout the USER'S Manual and have the following meaning:



### WARNING

This WARNING mark means that there is a possibility of death or serious injury if you ignore or do not follow the said instruction.



### CAUTION

This CAUTION mark means that there is a possibility of injury or physical damage if you ignore or do not follow the said instruction.

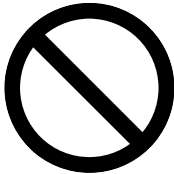

When marked with this symbol, "DO NOT ATTEMPT"



When marked with this symbol, "pay close attention to"



# WARNING

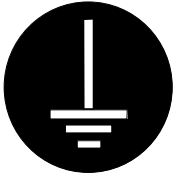

Ground the product with a correct ground source or you may be electrically shocked.



1. The Power source should be as follows:  
220 to 240V plus 6% or minus 10%, 50/60Hz, 20A or higher
2. Use a circuit with a dedicated breaker.
3. Install the product as close to the wall outlet as possible.
4. If you wish to move the printer, please contact your service personnel.



1. Do not remove the screw and do not open the cover if not instructed to do so in this User's Manual. If you ignore this warning, you may be burnt or receive an electric shock due to a hot item or electrically charged part inside of the printer.
2. Do not disassemble or tamper with the printer.  
It may result in a fire or an electrical shock.

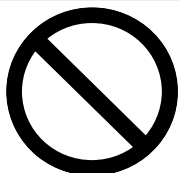

1. Do not plug in the printer into a multi-wire connector in which some other equipment is plugged into.  
It may cause a fire due to outlet overheating.
2. Do not damage the Power Cord by stepping on or placing heavy items on it.  
If the Power Cord is damaged, it may cause a fire or you may receive an electric shock. **REPLACE THE CORD IF DAMAGED!**

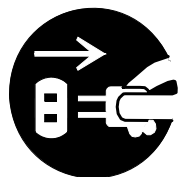

1. Do not put a flower vase, a flowerpot or any water-filled item on the product.  
Spilt water could cause a fire or an electric shock.
2. If the product generates an abnormal smell or noise, turn it off and unplug it from the wall electrical outlet immediately.



Do not throw the toner into a fire or other sources of heat, as it can explode.



# CAUTION



Do not install the printer in a humidified room or a dusty room. Also, do not install the printer on an unstable floor as injuries may occur.

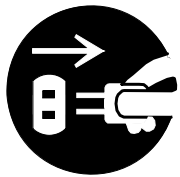

1. Unplug the printer before you move it. The power cord may be damaged and it may result in a fire or electric shock.
2. If you do not use the printer for a long duration (holidays, company shutdown) turn off and unplug the printer from the outlet for safety.

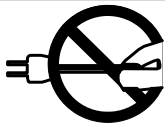

Do not pull the cord when you unplug the printer as you may damage the Power Cord.



There are hot items inside of the printer. Take great care not to touch these items when you remove mis-fed media.



Ventilate the room well if you print in a small area.

## POWER CORD INSTRUCTION

The installation of (or exchange to) a power plug which fits in the wall outlet of the installation location shall be conducted in accordance with the following:



### **WARNING**

Select a power plug which meets the following criteria;

- The plug has a voltage and current rating appropriate for the product's rating marked on its name plate.
- The plug meets regulatory requirements for the area.
- The plug is provided with a grounding pin or terminal.

If the appropriate plug does not fit the wall outlet in the installation, the customer shall install an appropriate outlet.

#### Connector Type:

Configuration	Standard	Rating	Usually found in
	IEC60320:C19	20A 250V (UL) 16A 250V (IEC)	

#### Plug Type: Model Rating 220-240V

Configuration	Standard	Rating	Usually found in
	NEMA6-20	20A 250V	North America (UL Listed)
	CEE7/7	16A 250V	European countries
	KS C 8305	16A 250V	Korea
	AS/NZS 3112	16A 250V	Australia New Zealand
	GB1002 GB2099.1	16A 250V	China
	IRAM 2073	16A 250V	Argentina

#### Cord Type

Standard	Rating	Usually found in
SJT 3X12AWG Long <4.5m	20A 250V	North America (UL Listed)
HO5VV-F 3X1.5mm <sup>2</sup>	16A 250V	European countries Argentina
RVV 3X1.5mm <sup>2</sup>	16A 250V	China

# TABLE OF CONTENTS

## Chapter 1 Before Use

---

	Page
1.1 Installation Requirements .....	1- 2
1.2 Originals Prohibited from Duplication .....	1- 3
1.3 Features .....	1- 4
1.4 Specifications .....	1- 5
1.5 Appearance .....	1- 7
1.5.1 Front view .....	1- 7
1.5.2 Left side view .....	1- 8
1.5.3 Rear view .....	1- 9
1.6 Specifications for the Printing Paper .....	1- 11
1.6.1 Papers not available to use .....	1- 11
1.6.2 Keeping the paper in the custody .....	1- 12
1.6.3 Treatment against environmental condition .....	1- 13

## Chapter 2 Basic Operations

---

	Page
2.1 Turning on the KIP C7800 .....	2- 2
2.2 Turning off the KIP C7800 .....	2- 4
2.3 Replacing the Roll Media .....	2- 6
2.4 Setting Cut Sheet Media to Bypass Feeder .....	2-11
2.4.1 Loading Small Size Sheet .....	2-12
2.4.2 Loading Large Size Sheet .....	2-14
2.5 Replacing the Toner Cartridge .....	2-16
2.6 Replacing the Waste Toner Box .....	2-20
2.7 Initial Cut (Straighten the leading edge of roll media) .....	2-24
2.8 Sleep Mode .....	2-26

## Chapter 3 Error Correction

---

	Page
3.1 Mis-feed Errors .....	3- 2
3.1.1 How to Remove Mis-fed Media .....	3- 3
3.2 Open Errors .....	3-11
3.2.1 Roll Deck 1 Open .....	3-11
3.2.2 Roll Deck 2 Open .....	3-11
3.2.3 Roll Deck 3 Open .....	3-12
3.2.4 Roll Deck 1 - Cutter Cover Open .....	3-12
3.2.5 Roll Deck 2 - Cutter Cover Open .....	3-13
3.2.6 Roll Deck 3 - Cutter Cover Open .....	3-13
3.2.7 Sheet Bypass Open .....	3-14
3.2.8 Left Door Open .....	3-14

3. 2. 9	Rear Door Open .....	3-15
3. 2.10	Fuser Exit Door Open .....	3-15
<b>3. 3</b>	<b>Other Operator Call Error .....</b>	<b>3-16</b>
3. 3. 1	Printer out of paper .....	3-16
3. 3. 2	Printer out of toner .....	3-16
3. 3. 3	Printer waste toner bottle full .....	3-17
3. 3. 4	Web Cleaner Empty .....	3-18
<b>3. 4</b>	<b>Service Call Errors .....</b>	<b>3-19</b>

# Chapter 1

## Before Use

	page
<b>1.1 Installation Requirements</b> .....	1- 2
<b>1.2 Originals Prohibited from Duplication</b> .....	1- 3
<b>1.3 Features</b> .....	1- 4
<b>1.4 Specifications</b> .....	1- 5
<b>1.5 Appearance</b> .....	1- 7
1.5.1 Front view .....	1- 7
1.5.2 Left side view .....	1- 8
1.5.3 Rear view .....	1- 9
<b>1.6 Specifications for the Printing Paper</b> .....	1- 11
1.6.1 Papers not available to use .....	1- 11
1.6.2 Keeping the paper in the custody .....	1- 12
1.6.3 Treatment against environmental condition .....	1- 13

# 1.1 Installation Requirements

---

The following conditions are required for installation of the equipment.

- (1) Power source should be as follows (according to your region).  
U.S.A. / Europe ----- 220 to 240V (+6% to -10%), 20A or higher, and 50/60Hz
- (2) The equipment must be on an exclusive circuit.  
The outlet must be near the equipment and easy accessible.
- (3) Make sure to connect this equipment to a grounded outlet.
- (4) The site temperature range = 15 to 27 degrees centigrade, with the humidity between 20% to 70% RH (NON CONDENSING).  
Keep the equipment away from water sources, boilers, humidifiers or refrigerators.
- (5) The installation site must not have open flames, dust or ammonia gases.
- (6) The equipment should not be exposed to the direct sunlight.  
Please draw curtains to block any sunlight.
- (7) Ozone will be generated while this equipment is in use, although the quantity generated is within safe levels. (see certifications)  
Ventilate the room, if required.
- (8) Levelling Bolts on the bottom of the KIP C7800 should touch the floor correctly.  
And the equipment must be levelled.  
Floor strength must be ample to sustain the weight of the equipment.
- (9) Keep ample room around the equipment to ensure comfortable operation.  
Required space is noted.

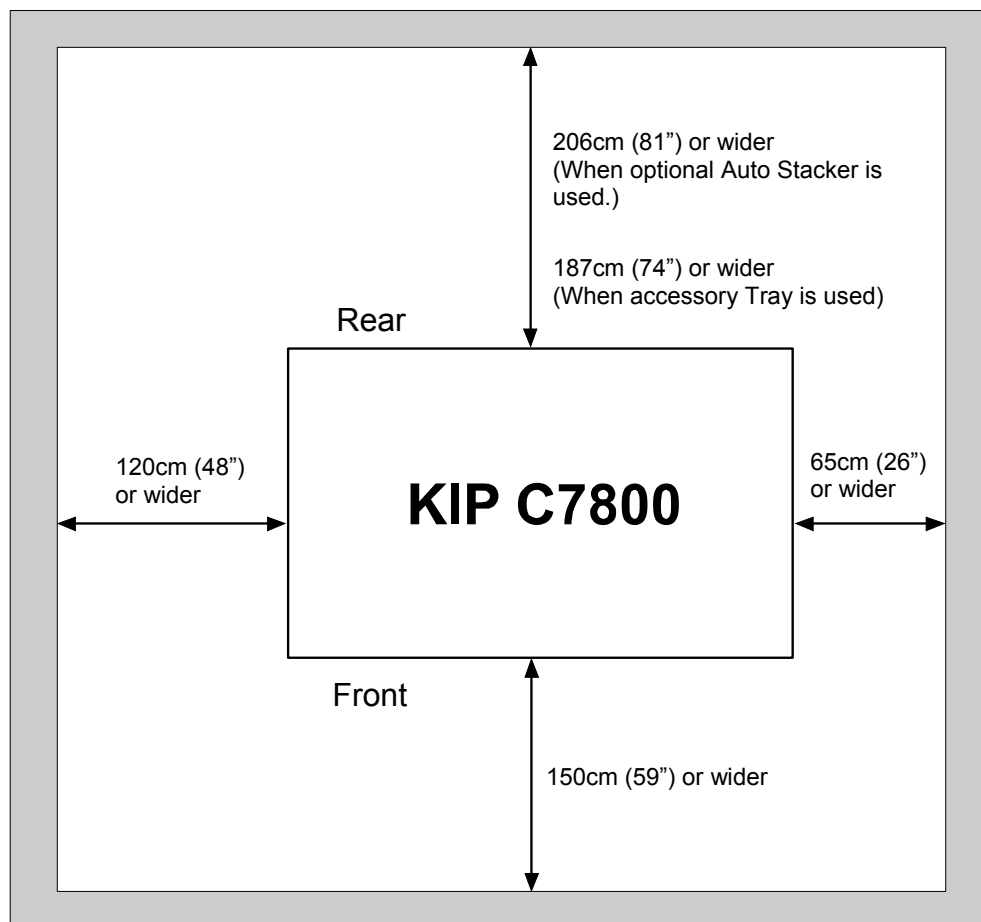

# **1.2 Originals Prohibited from Duplication**

It may be illegal to duplicate or copy certain types of originals and you may be punished by local or regional laws, if copies are made of these types of originals.

Please be aware of your local or regional laws and which originals they forbid you to duplicate.

## Some Examples:

[Originals prohibited from copying by the law(s)]

1. Do not copy Currency (Bill, Money, Bank Note, etc.), Government issued Negotiable Instruments (National Bonds, Security, Local Debt Bonds, etc.).
2. Do not copy Foreign Currency or Foreign Negotiable Instruments.
3. Do not copy unused postal stamps or government postcards without permission to make replica from said Governments.
4. Do not copy Government issued revenue stamps, certificate stamps that are prescribed by Liquor Tax Act or the Commodity Tax Act.

[Special items which require your attention]

1. The government issues warnings if you are to copy private issued securities (stock certificate, draft, check, goods ticket, etc.), commutation ticket or book of tickets, excluding that some specific company copies such originals as many as it requires for its own business.
2. We recommend you not copy originals as government issued passports, public or private issued licenses, automobile inspection certification, ID and tickets passes or meals.

[Originals protected by the copyright]

It is prohibited to copy originals such as books, music, paintings, printed copies, maps, drawings, movie posters and pictures which are protected by the copyright laws.

Please see your local or regional laws.

# 1.3 Features

---

- (1) Electro Photographic full color LED printer
- (2) Supports wide range of print size, 914mm (36") width x 6,000mm length maximum, 297mm (11") x 210mm (8.5") minimum.
- (3) 600dpi print resolutions produce the highest quality images controlled by an advanced KIP Image Process System.
- (4) Drastically reliable media transportability brought by Media Feed Belt Conveyor system allows stability of creating excellent image quality and long media feeding.
- (5) CMYK process systems in tandem, resulting in smaller footprint, provides high performance productivity of 4.7 prints/minute of A0 color printing.  
(Color Print: 100mm/s maximum, Mono: 120mm/s)
- (6) Four color toner allows a broad selection of media type for Folor printing, such as a plain paper / bond roll media, saving consumables cost than a wide format inkjet printer.
- (7) Prints are available to use immediately, free from drying time and wrinkling by the KIP C7800 dry toner.
- (8) Easy access to the front USB port allows the users for efficient productivity "USB to Print".
- (9) Touch screen Operating Panel offers an intuitive UI for advanced operability to configure and submit a print job.
- (10) Includes Print Tray for stacking prints as a standard accessory. High capacity Auto Stacker is available (option).

# 1.4 Specifications

Subject	Specification														
Model	KIP C7800														
Type	Console														
Printing method	LED Array Electro Photography														
Color	CMYK														
Photoconductor	Organic Photoconductive Drum														
Print speed	Color : 100mm / sec standard medias 60mm/sec for special medias Mono : 120mm / second														
Exposure method	Multi-Level (tone number 9) LED Print Head														
Resolution	600dpi x 2400dpi														
Print width	Maximum : 914mm (36 inches) Minimum : 297mm (11 inches)														
Print length	<p>Maximum :</p> <table border="1" data-bbox="507 689 1257 864"> <tr> <td rowspan="2">Plain Paper / Bond</td> <td>5x Standard</td> <td>Roll Deck 3</td> </tr> <tr> <td>2x Standard</td> <td>Roll Deck 1, 2</td> </tr> <tr> <td>Tracing Paper / Vellum</td> <td>1x Standard</td> <td></td> </tr> <tr> <td>Film</td> <td>1x Standard</td> <td></td> </tr> <tr> <td>Glossy Paper</td> <td>1x Standard</td> <td></td> </tr> </table> <p>Minimum : 210mm (8.5 inches)</p> <p>NOTE : If the print is longer than 6m, KIP does not guarantee image quality or the reliability of media feeding system.</p>	Plain Paper / Bond	5x Standard	Roll Deck 3	2x Standard	Roll Deck 1, 2	Tracing Paper / Vellum	1x Standard		Film	1x Standard		Glossy Paper	1x Standard	
Plain Paper / Bond	5x Standard		Roll Deck 3												
	2x Standard	Roll Deck 1, 2													
Tracing Paper / Vellum	1x Standard														
Film	1x Standard														
Glossy Paper	1x Standard														
Warm up time	Shorter than 4 minutes (At 23 degrees centigrade, 60% RH and 220V)														
First print time	Shorter than 33 seconds (36 x 48 inches)														
Fusing method	Heat roller fusing														
Development	Contact type mono component non-magnetic development system (Initial toner is unnecessary. One toner cartridge contains 1kg.)														
Charging method	Corona														
Transfer method	Transfer roller														
Media feeding method	Automatic (*3 Roll Decks) and manual (**20 cut sheets capacity)  * Image quality on A3, 15", 12", 11" width roll media is guaranteed with using Roll Deck 3 only ** A2 - A4 (24" - 11") in Portrait orientation only														
Input power	220 to 240V (+6% to -10%), 20A and 50/60Hz														
Interface	Ethernet 10BASE-T, 100 BASE -TX, 1000 BASE-T USB 2.0 (5VDC max)														
Power consumption	On 230V, 50/60Hz 3.6 kwh (Maximum) Stand by ..... 0.8 Kwh (Average) Printing ..... 2.2 Kwh (Average) Warm up ..... 3.4 Kwh (Average)														
Acoustic noise	Less than 65db (Printing) NOTE : Impact noise such as cutting sound is excluded. Less than 60db (Stand by)														
Ozone	Less than 0.05ppm (Average of 8 hours)														
Dimensions	1376mm (Width) x 790mm (Depth) x 1450mm (Height)														
Weight	About 540kg														

Subject	Specification
Media	Plain Paper / Bond: Color mode: 70 to 150g/m <sup>2</sup> * For heavier media (90 to 150g/m <sup>2</sup> ), use media type setting "Heavy". Mono mode: 70 to 75g/m <sup>2</sup>
Environmental condition	Temperature ..... 15 to 27 degrees centigrade Humidity ..... 20 to 70% RH
Storage condition of consumables	Print media ..... Wrap the media surely to shut out the humidity. Toner ..... Keep the toner cartridge away from the direct sunlight, and store it in the condition of 0 - 35 °C and 10 - 85% RH.

** NOTE**

These specifications may be changed without notice.

# 1.5 Appearance

## 1.5.1 Front view

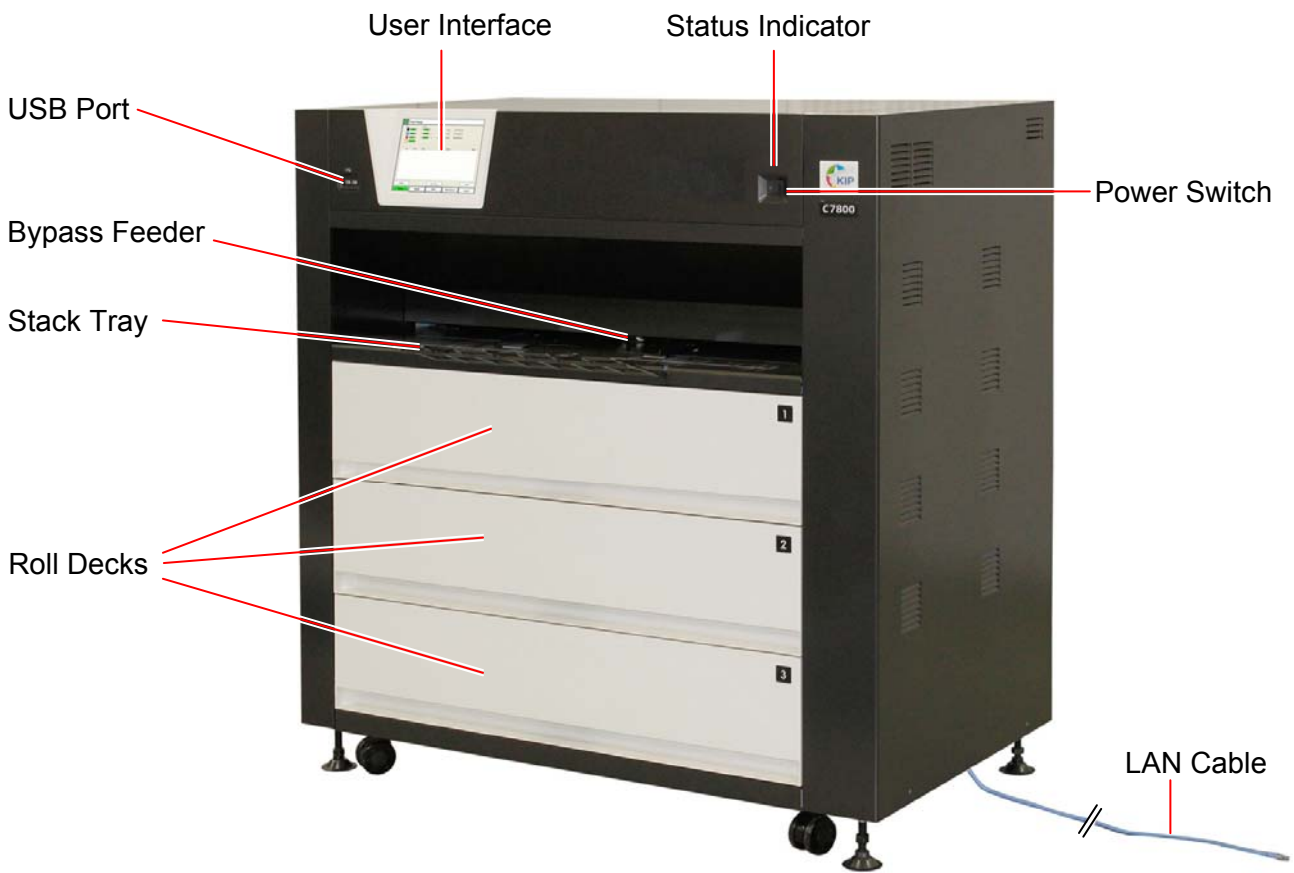

Name of part	Function																								
Power Switch	Turns on/off the KIP C7800.																								
Bypass Feeder	Feeds in the cut sheet media. 20 sheets can be set at once if the media is A2 (594mmx420mm) or smaller. (24" or narrower)																								
User Interface	This is a Touch Screen, and many kinds of user operation are available. <b>PLEASE DO NOT</b> push the LCD area too strong.																								
Stack Tray	Supports cut sheets loaded on Bypass Feeder.																								
Roll Decks	3 roll media can be set totally.																								
USB Port	Your USB flash memory storage can be installed here. 5VDC max.																								
LAN Cable	Connects to the network. (Purchase a LAN Cable separately)																								
Status Indicator	LED indicator above the power switch indicates the following printer status. <table border="1" data-bbox="549 1742 1465 2004"> <thead> <tr> <th>Color</th> <th>Condition</th> <th>Status</th> </tr> </thead> <tbody> <tr> <td>Green</td> <td>Light</td> <td>Ready, Printing</td> </tr> <tr> <td>Green</td> <td>Blink</td> <td>Warming up.</td> </tr> <tr> <td>Orange</td> <td>Light</td> <td>Operator Call Error</td> </tr> <tr> <td>Red</td> <td>Light</td> <td>Service Call Error</td> </tr> <tr> <td>Blue</td> <td>Light</td> <td>Warm sleep</td> </tr> <tr> <td>Blue</td> <td>Blink</td> <td>Cold sleep</td> </tr> <tr> <td>light purple</td> <td>Blink</td> <td>When printer is power-off and print controller is still power on.</td> </tr> </tbody> </table>	Color	Condition	Status	Green	Light	Ready, Printing	Green	Blink	Warming up.	Orange	Light	Operator Call Error	Red	Light	Service Call Error	Blue	Light	Warm sleep	Blue	Blink	Cold sleep	light purple	Blink	When printer is power-off and print controller is still power on.
Color	Condition	Status																							
Green	Light	Ready, Printing																							
Green	Blink	Warming up.																							
Orange	Light	Operator Call Error																							
Red	Light	Service Call Error																							
Blue	Light	Warm sleep																							
Blue	Blink	Cold sleep																							
light purple	Blink	When printer is power-off and print controller is still power on.																							

## 1. 5. 2 Left side view

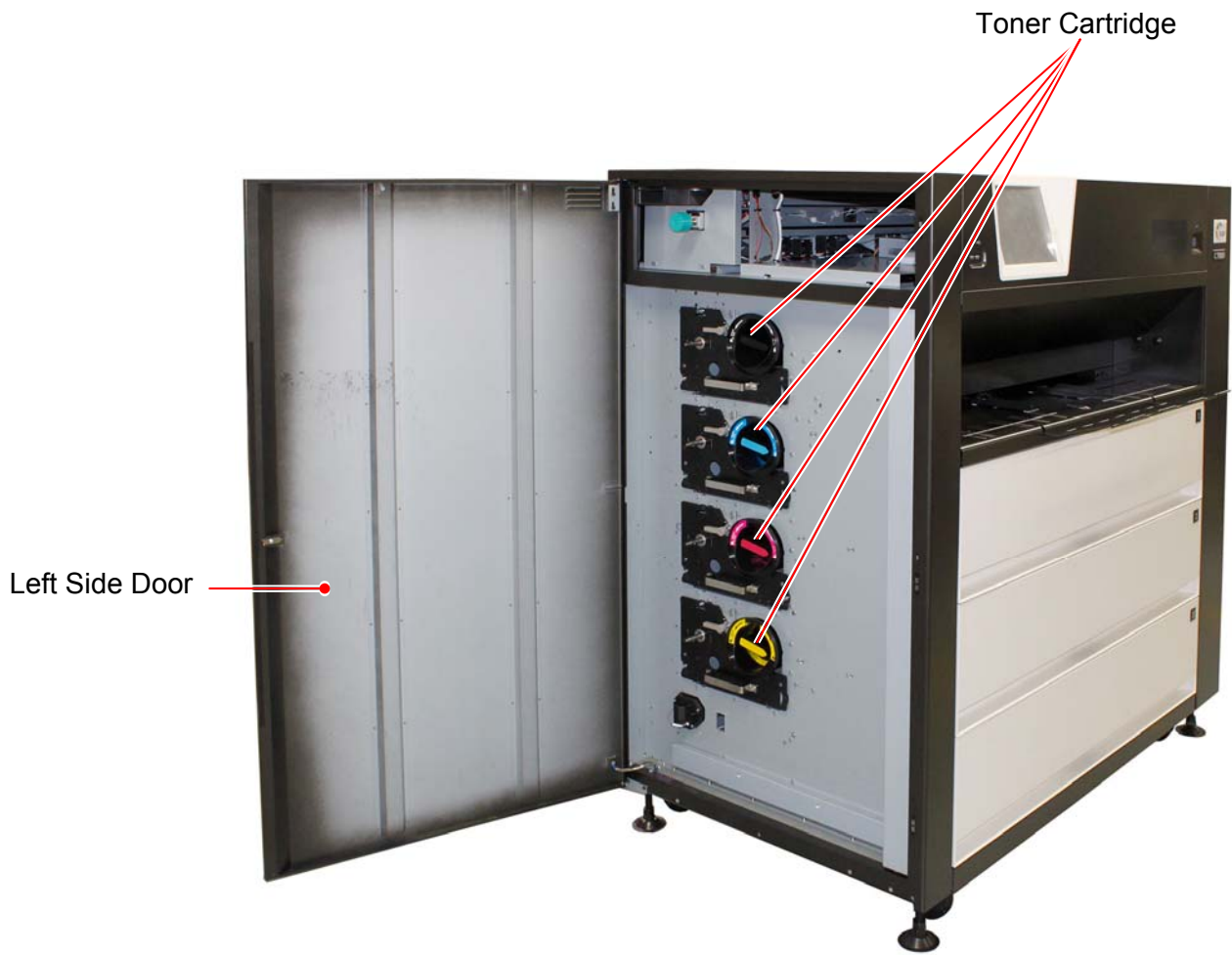

Name of part	Function
Toner Cartridge	4 Toner Cartridges (cyan, magenta, yellow and black) supplies the toner little by little.
Left Side Door	Open here to replace the Toner Cartridge.

### 1.5.3 Rear view



Name of part	Function
Stacker Port	For a dedicated Auto Stacker for the KIP C7800 (DC24V 2A)
Fuser Exit Door	Prints come from the opening on this. Open here to clear a print jam in Fuser Unit.
Waste Toner Box	Collects the wasted toner.
Breaker	It is possible to shut off supplying the AC power.
Power Cord	To be connected to the wall outlet alone.  NOTE : Specification for the power cord used in North America Use the following type of power cord (UL-Listed). (1) Rating 250VAC, 20A (2) Plug type NEMA6-20 (3) Socket type IEC60320 : C19 (4) Cord SJT 3xAWG12 L <4.5m (5) UL-Listed

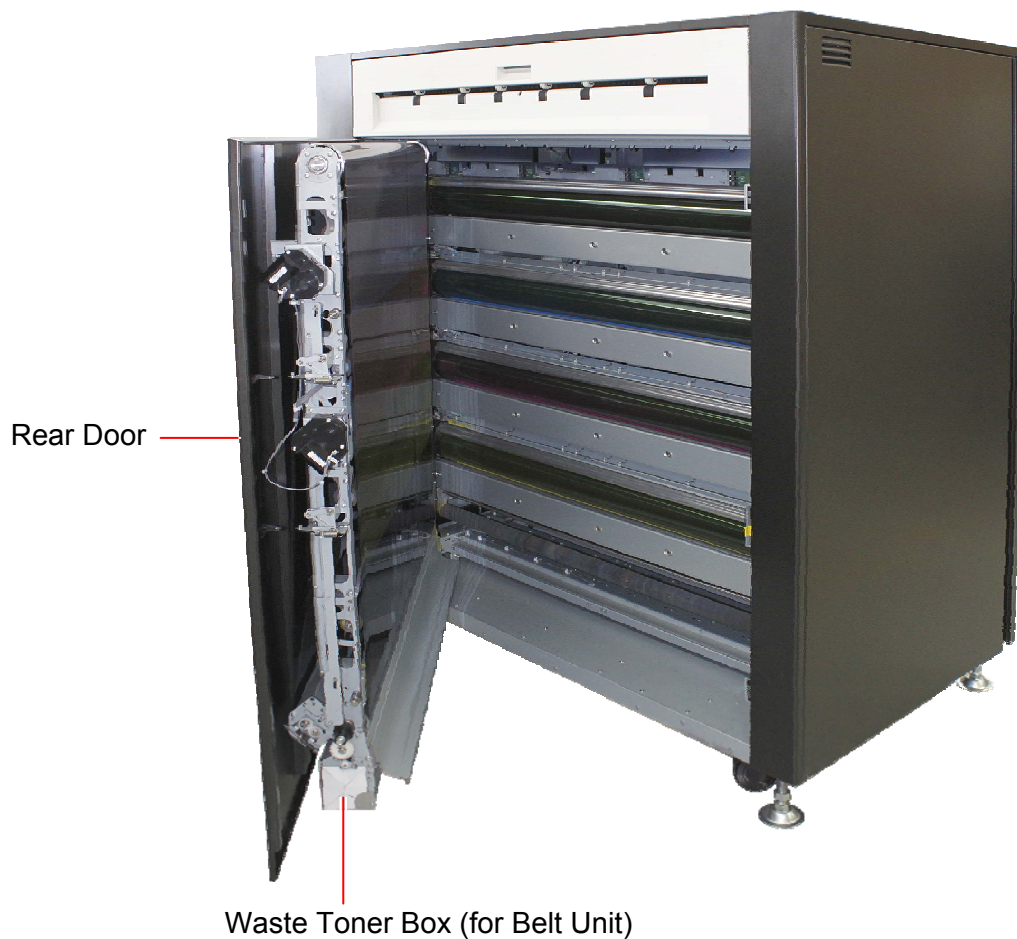

Name of part	Function
Rear Door	Can access the mis-fed media and the Waste Toner Box for Belt Unit by opening Rear Door.
Waste Toner Box (for Belt Unit)	Collects the wasted toner.

# 1. 6 Specifications for the Printing Paper

## 1. 6. 1 Papers not available to use

Do not use the following kinds of printing paper. Doing so may damage the print engine.

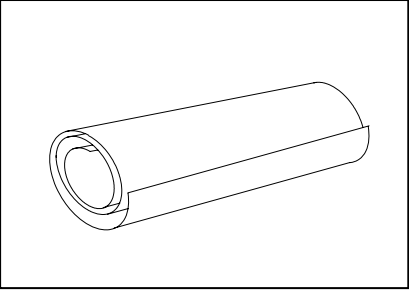
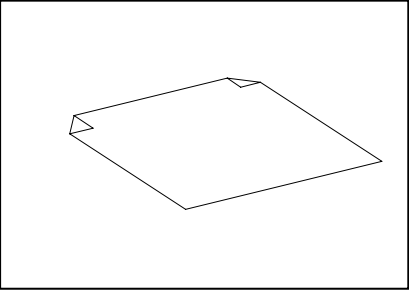
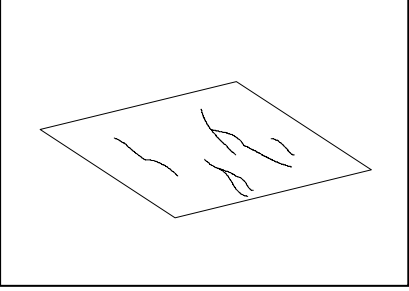
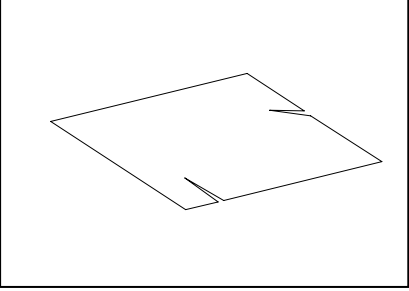
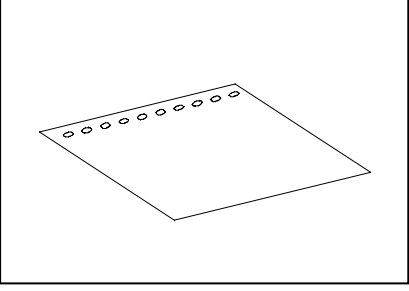
Excessively curled (a diameter of 50 mm or less)	
Folded	
Creased	
Torn	
Punched	

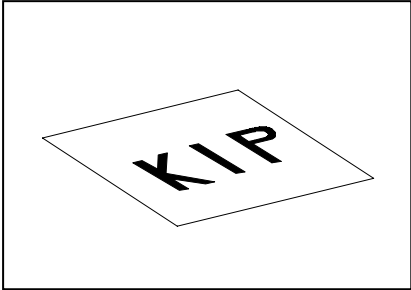
Pre-printed	
Extremely slippery	
Extremely sticky	
Extremely thin and soft	
OHP Film	

### **⚠ CAUTION**

Do not use the paper with staple, or do not use such conductive paper as aluminium foil and carbon paper.

The above may result in a danger of fire

### **⚠ NOTE**

- (1) Print image may become light if printed on a rough surface of the paper.
- (2) Print image may become defective if the print paper has an excess curl.
- (3) It will become a cause for paper mis-feed, defective print image or paper creasing if you use a paper that does not satisfy the specification.
- (4) Do not use a paper of which surface is very special, such as thermal paper, art paper, aluminium foil, carbon paper and conductive paper.
- (5) Do not use papers with unpacked (exposed in high / low temperature & humidity) in a long period. Such papers may result in mis-feed, defective image or paper creasing.
- (6) Tracing paper exposed to air over a long period tends to cause a defective printing. Removing one round on the surface of the tracing roll paper from the beginning is recommended.  
Refer to [2.3 Replacing Roll Media].

## **1. 6. 2 Keeping the paper in the custody**

Keep the paper in the custody taking care of the following matters.

1. Do not expose the paper to the direct sunlight.
2. Keep the paper away from high humidity. (It must be less than 70%)
3. Put the paper on a flat place
4. If you will keep the paper in the custody, which you have already unpacked, put it into the polyethylene bag to avoid the humidity.

## 1. 6. 3 Treatment against environmental condition

Take a necessary treatment according to the environmental condition as shown below.

Humidity(%)	Possible problem	Necessary treatment
Low ↑	“Void of image”, “crease of paper” and other problems occurs when you print with plain paper and tracing paper.	1. Install the humidifier in the room, and humidify the room air. 2. Remove the paper from the machine right after the completion of print, and keep it in a polyethylene bag.
40%	“Void of image” occurs when you print with tracing paper.	If you will not make print soon, remove the tracing paper from the machine and keep it in a polyethylene bag.
		Remove the paper from the machine after everyday use, and keep it in a polyethylene bag.
70%	“Void of image” occurs when you print with plain paper and tracing paper.	If you will not make print soon, remove the tracing paper from the machine and keep it in a polyethylene bag.
↓ High	“Void of image”, “crease of paper” and other problems occurs when you print with plain paper and tracing paper.	Remove the paper from the machine right after the completion of print, and keep it in a polyethylene bag.

# Chapter 2

## Basic Operations

	page
<b>2.1 Turning on the KIP C7800</b> .....	2- 2
<b>2.2 Turning off the KIP C7800</b> .....	2- 4
<b>2.3 Replacing the Roll Media</b> .....	2- 6
<b>2.4 Setting Cut Sheet Media to Bypass Feeder</b> .....	2-11
2.4.1 Loading Small Size Sheet .....	2-12
2.4.2 Loading Large Size Sheet .....	2-14
<b>2.5 Replacing the Toner Cartridge</b> .....	2-16
<b>2.6 Replacing the Waste Toner Box</b> .....	2-20
<b>2.7 Initial Cut (Straighten the leading edge of roll media)</b> .....	2-24
<b>2.8 Sleep Mode</b> .....	2-26

## 2. 1 Turning on the KIP C7800

---

1. Plug the KIP C7800 to an exclusive wall outlet.

### NOTE

Please confirm the outlet satisfies the following condition before plugging the KIP C7800 into.

220-240V (+6% to -10%), 20A, and 50/60Hz

2. Press “I” side of the Power Switch on the front to turn on the KIP C7800.

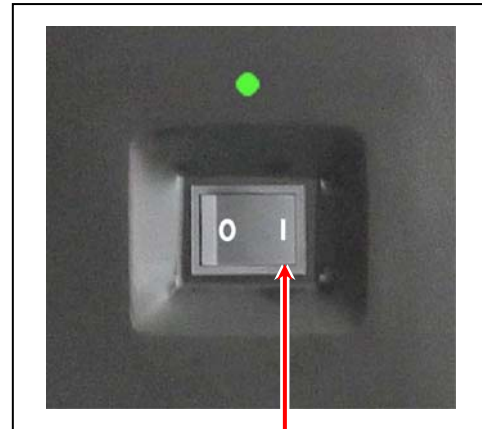

Press this side

3. The Status Indicator above the Power Switch flashes green while warming up.

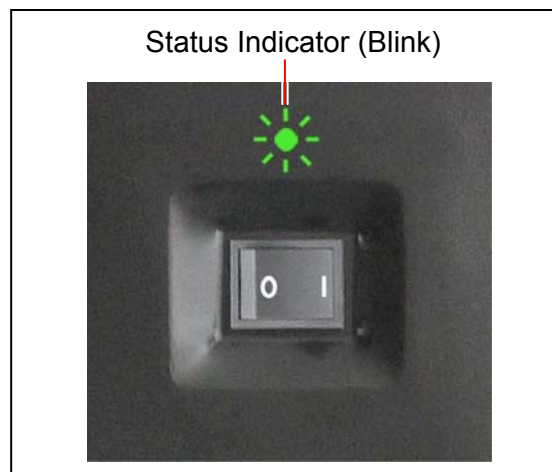

### NOTE

The machine does not operate at all if the circuit breaker is turned off. Flip up the circuit breaker switch to turn on the power supply.



4. The KIP C7800 will get ready about 3 minutes after turning on. The Status Indicator stops blinking and lights green when ready. Make a copy or print from outer devices.

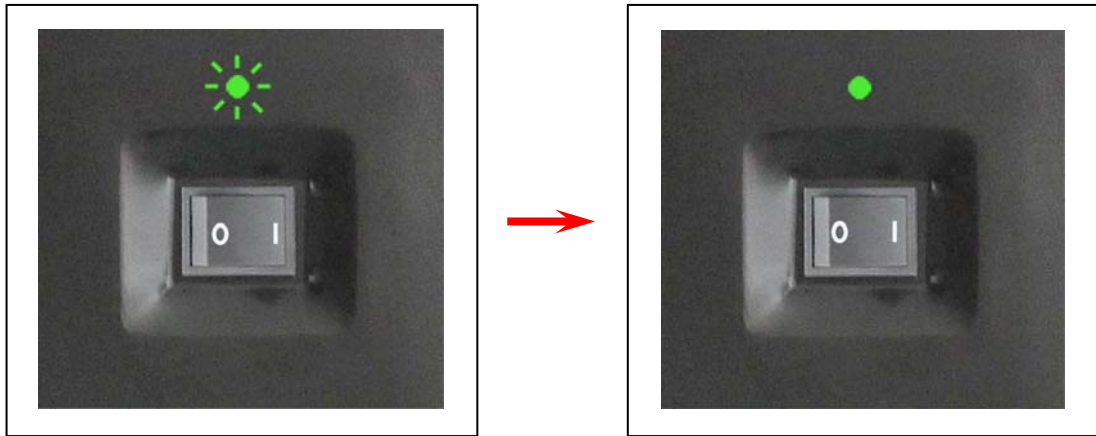

## 2. 2 Turning off the KIP C7800

1. Press “○” side of the Power Switch on the front to turn off the KIP C7800.

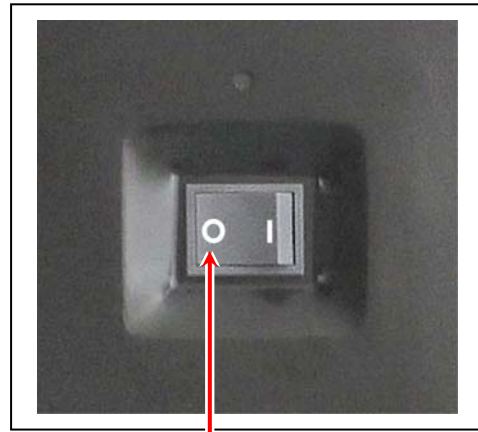

Press this side

2. The Status Indicator flashes light purple while the embedded controller unit is shutting down. It will turn off in 2 minutes.

Status Indicator (blinking)

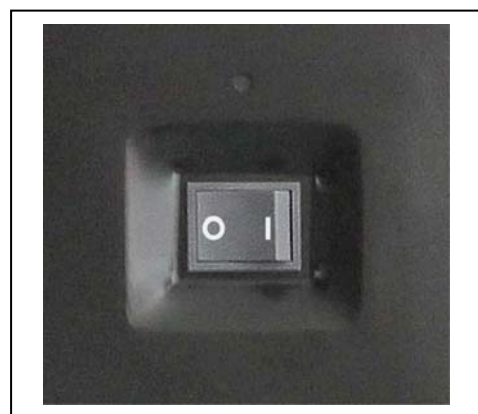
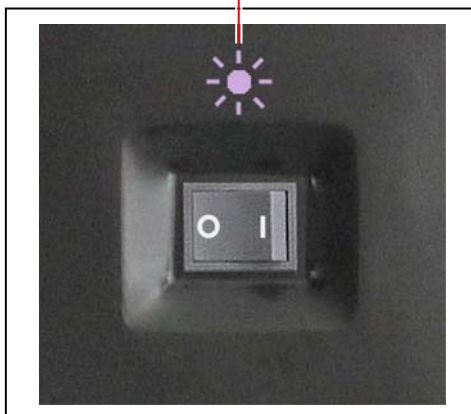

### ⚠ NOTE

The controller unit starts shutdown process after turning off the KIP C7800, and it will take about 2 minutes until complete shut down. Do not unplug the KIP C7800 from the outlet for about 2 minutes after turning off therefore. The controller unit may be broken if the KIP C7800 is unplugged before the completion of shut down process.



3. If you completely shut the power supply due to a long vacation or the machine's transport, turn off the circuit breaker and then remove the power cable from the machine.

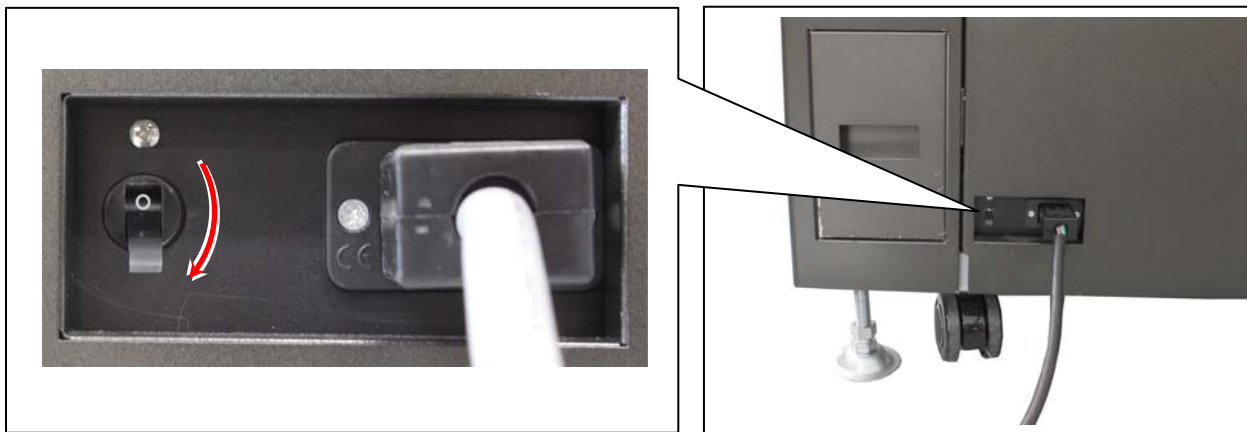

## 2.3 Replacing the Roll Media

1. Pulling up the handle to unlock the Roll Deck, and draw out the deck.



2. Remove the Roll Spool from the Roll Deck.



### **NOTE**

Lift up the Roll Spool with supporting horizontally.

3. With pressing the green lever to the arrow direction (outside), remove the roll core from the Roll Spool.



**NOTE**

Two projection parts in the middle of Roll Spool have a sharp tip. Be careful after you remove a roll core.

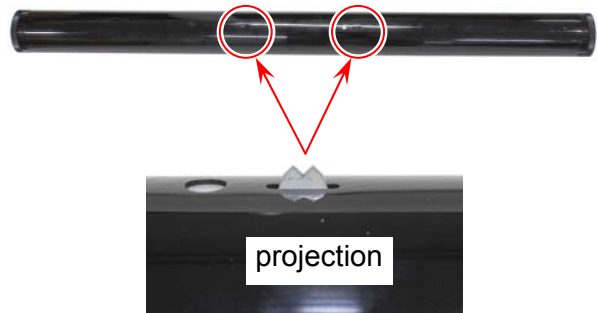

4. With pressing up the green lever, insert the Roll Spool into a new roll media.



**NOTE**

Set the roll media in the correct direction.



Correct



Not Correct



7. Draw out the concerned Roll Deck fully.

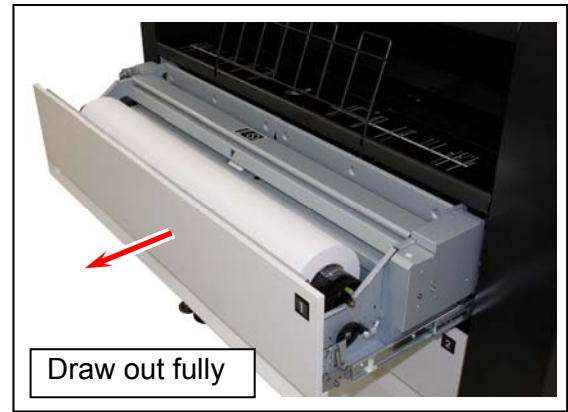

8. Insert the leading edge between the feeding rollers. It will automatically go into the roll media's standby position. (Auto Media Loading)

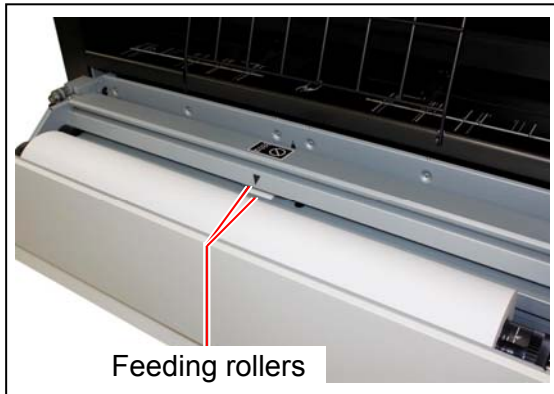

### **⚠ NOTE**

- (1) Some roll media are taped at its leading edge. Even if you remove the tape, glue may remain on the leading edge. This would mess or damage the media path. Before using such a roll media, cut off some amount of the leading edge using a cutter knife and discard the portion with glue.
- (2) If Auto Media Loading does not start, clear Door Open Error such as Bypass Feeder, Left Side Door, Rear Door or Paper Exit Door.

9. Make sure of the followings prior to an initial cut.
- The Roll Deck drawer which you want an initial cut is fully opened
  - The upper Roll Deck drawer are firmly closed

**! NOTE**

For Roll Deck 2 and 3, the upper drawer should be closed. If it is open, the leading edge would have an initial cut improperly by touching its bottom.

10. Press the Initial Cut button.  
The leading edge automatically proceeds and has a cut off. The portion will be ejected upward.



11. Remove the portion. Close the Roll Deck.



12. Define the media information (media type and width) with using the touchscreen.

**! NOTE**

Incorrect settings lead to unwanted print results (fusing defect, improper image quality).

## 2. 4 Setting Cut Sheet Media to Bypass Feeder

Cut sheet media can be fed from the Bypass Feeder. Each size has its own availability for orientation and multi-feeding respectively as follows.

### Metric

Media size	Available orientation (Length x Width)	Availability of multi-feeding	Remarks
A4	Landscape (210mm x 297mm)	Available	
A3	Landscape (297mm x 420mm)	Available	
A2	Landscape (420mm x 597mm)	Available	
A1	Landscape (597mm x 841mm)	Not available	
A0	Portrait (1189mm x 841mm)	Not available	
841mm wide (Not standard length)	Portrait & Landscape	Not available	Must be longer than 210mm at least.

### Inch

Media size (Length x Width)	Available orientation	Availability of multi-feeding	Remarks
8.5" x 11"	Landscape	Available	
9" x 12"	Landscape	Available	
11" x 17"	Landscape	Available	
12" x 18"	Landscape	Available	
17" x 22"	Landscape	Available	
18" x 24"	Landscape	Available	
30" wide (Not standard length)	Portrait & Landscape	Not available	Must be longer than 210mm at least.
34" wide (Not standard length)	Portrait & Landscape	Not available	Must be longer than 210mm at least.
36" wide (Not standard length)	Portrait & Landscape	Not available	Must be longer than 210mm at least.

Media size	Available orientation	Availability of multi-feeding	Remarks
A	Landscape (8.5" x 11")	Available	
B	Landscape (11" x 17")	Available	
C	Landscape (17" x 22")	Available	
D	Landscape (22" x 34")	Not available	
E	Portrait (34" x 44")	Not available	

### NOTE

- (1) Availability of orientation for each media size is illustrated on the Bypass Feeder. Please follow the illustration when setting the cut sheet media.
- (2) The upper larger signs are for Landscape, the lower smaller are Portrait.
- (3) Multi-feeding is available with cut sheet media in a smaller size. Refer to [2.4.1 Loading Small Size Sheet].

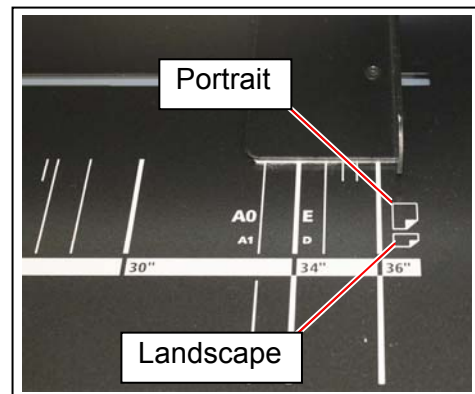

## 2. 4. 1 Loading Small Size Sheet

Multi-feeding is available with cut sheet media in a small size.  
“Small sizes” are as follows.

Metric : A4 (210mm x 297mm)  
A3 (297mm x 420mm)  
A2 (420mm x 594mm)

Inch : 8.5” x 11” / 9” x 12”  
11” x 17” / 12” x 18”  
17” x 22” / 18” x 24”  
A size / B size / C size

### ! NOTE

- (1) Do not attempt to make multi-feeding with a wider media than the above ones as it will cause a mis-feed or duplicate feeding. The internal mechanism might be broken in the worst case.
- (2) Do not leave the cut sheet media for a long time on the Bypass Feeder as it will get moisture, which will result in a mis-feed or image defect. (Put the media in a plastic bag to avoid moisture.)
- (3) Only landscape position is available in case of multi-feeding.
- (4) Use the Stack Tray for a sheet jutting from the Bypass Feeder. (longer than 420mm / 17”)

1. Be sure that the manual feed should be activated. If not, enter “Configuration” in the UI screen and set “Bypass” button to [Enabled].

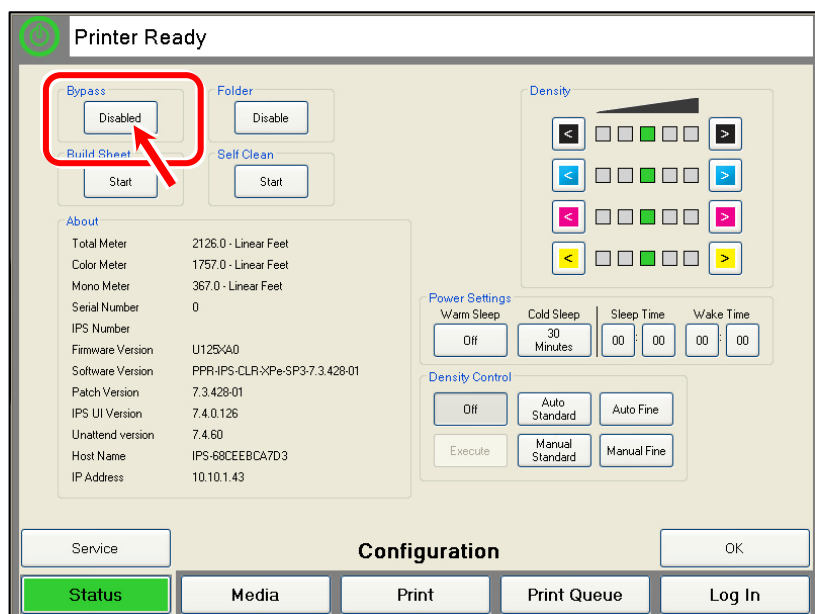

2. Install the Stack Tray as needed.



3. Sliding left and right, place the cut sheet guides properly according to the size of cut sheet media.



4. Arrange the edges of multiple media, put them on the Bypass Feeder by landscape position, and move them forward until contacted to feeding roller.

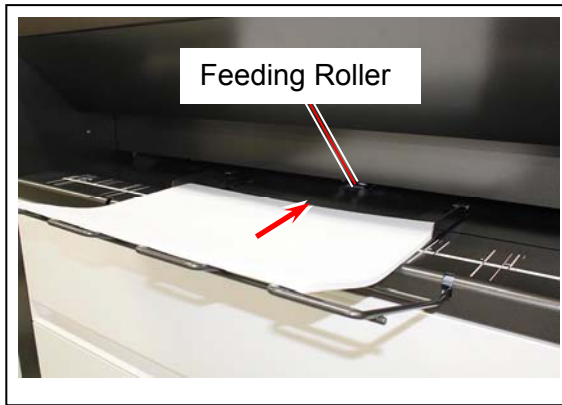

**NOTE**

As curled cut sheet media will cause a mis-feed, straighten the media as far as possible before printing. And set the media by “curl down” direction as a mis-feed can be avoided. Setting of media by “curl up” direction tends to result in a mis-feed.



Correct (curl down)



Incorrect (curl up)

5. Configure the correct media size setting according to the actual sheet(s) in the UI screen. See your system reference for media source information.

## 2. 4. 2 Loading Large Size Sheet

A large cut sheet media can not be fed by multi-feeding.  
Please feed it singularly as instructed in below.  
“Large sizes” are as follows.

Metric : A1 landscape (594mm x 841mm)  
A0 portrait (1189mm x 841mm)  
841mm wide (Non standard length)

Inch : 30” wide (Non standard length)  
34” wide (Non standard length)  
36” wide (Non standard length)  
D size / E size

### NOTE

Do not leave the cut sheet media for a long time on the Bypass Feeder as it will get moisture, which will result in a mis-feed or image defect. (Put the media in a plastic bag to block the moisture.)

1. Be sure that the manual feed should be activated. If not, enter “Configuration” in the UI screen and set “Bypass” button to [Enabled].

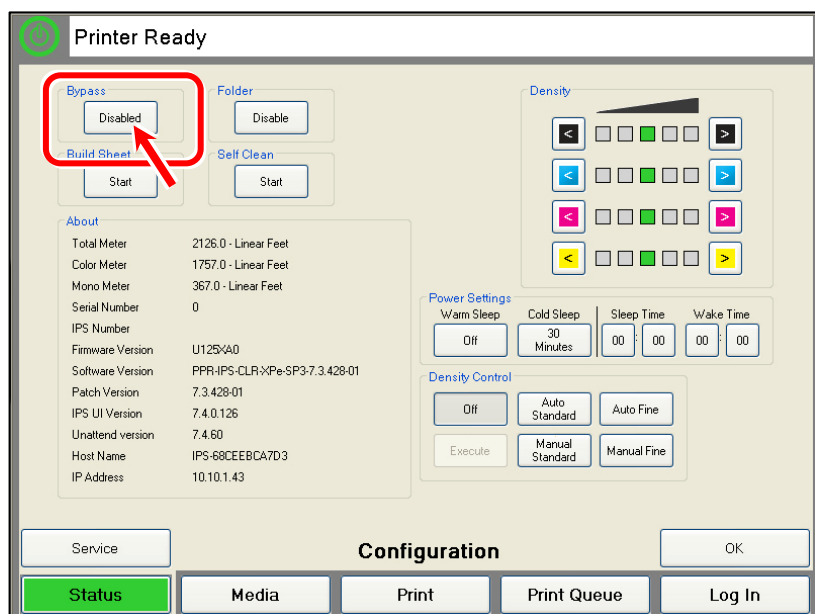

2. Sliding left and right, place the cut sheet guides properly according to the size of cut sheet media.

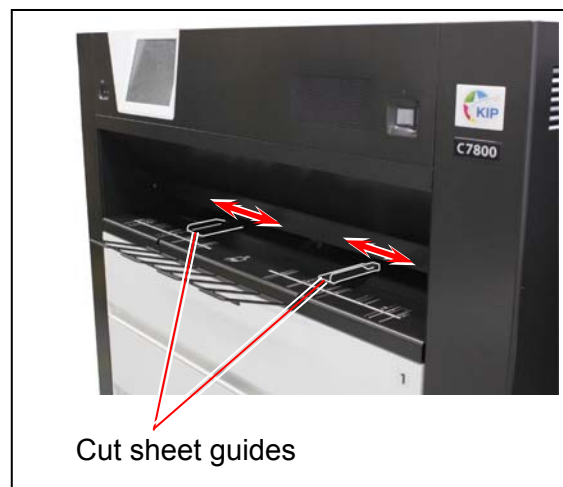

- Put the media on the Bypass Feeder, and move it in the direction of arrow until contacted to the feeding roller.  
The feeding rollers rotate automatically to place the cut sheet media at the starting position.

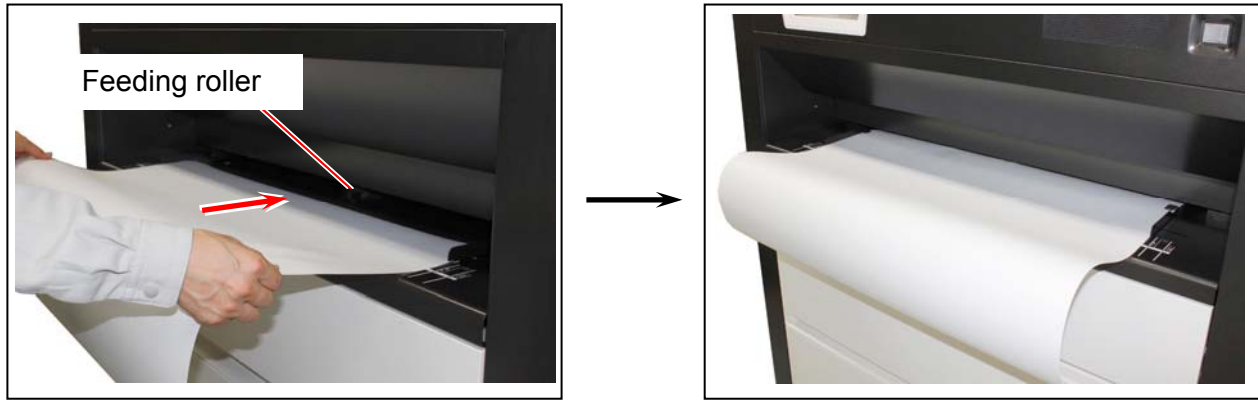

- Output a copy/print job from the output device.

**NOTE**

As curled cut sheet media will cause a mis-feed, straighten the media as far as possible before printing.  
And also please set the media by “curl down” direction as a mis-feed can be avoided.  
Setting of media by “curl up” direction tends to result in a mis-feed.



Correct (curl down)



Incorrect (curl up)

- Configure the correct media size setting according to the actual sheet(s) in the UI screen.  
Refer to your system reference for media source information.

## 2.5 Replacing the Toner Cartridge

### NOTE

Toner Cartridge should be replaced only when the UI screen says “Toner Empty”. Replacing one if not otherwise would cause an incorrect estimation of the remaining amount of toner in the machine.

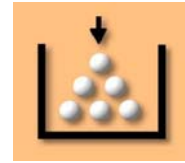

1. Open the Left Side Door.



2. Rotate the Toner Cartridge to the arrow direction until it stops.  
Pull and remove the Toner Cartridge from the machine.

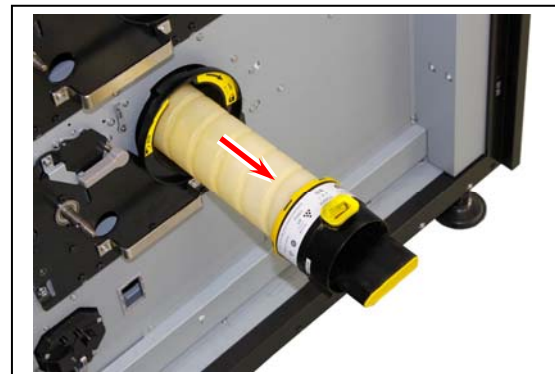
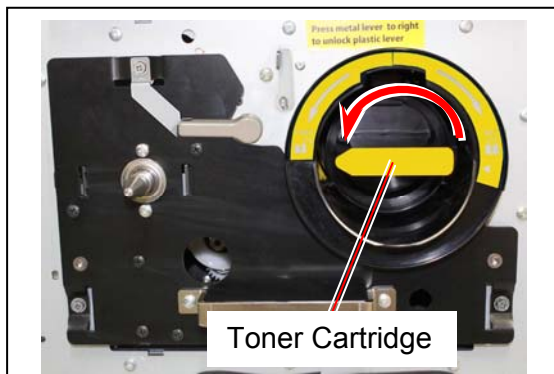

### NOTE

- (1) Toner Cartridge can not be removed if not rotated 180 degrees completely as the above.
- (2) Do not hold the ventral region of Toner Cartridge. Otherwise the toner may blow out from the supply hole.

See next page

## **!** NOTE

- (3) Be careful not to direct the supply hole to the floor after removing the Toner Cartridge. Otherwise toner will come out from the supply hole.

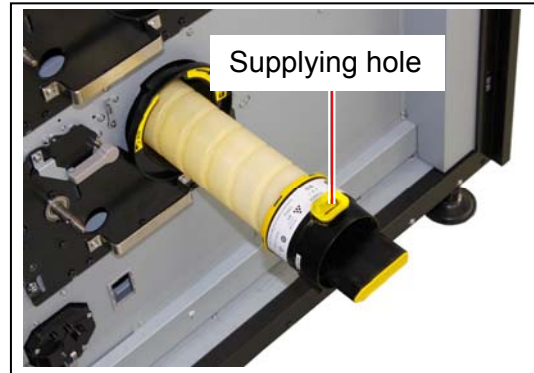

- (4) Do not remove Toner Cartridge with unused toner portion inside. Otherwise the toner portion may come out from the supply hole.
- (5) The Toner Cartridge should be returned to your service technician or should be discarded according to your local regulations.

## **!** WARNING

Do not discard it as a flammable. Toner will explode if thrown into the fire.

3. Choose the new Toner Cartridge of the same color, and shake it enough to loosen the toner well.

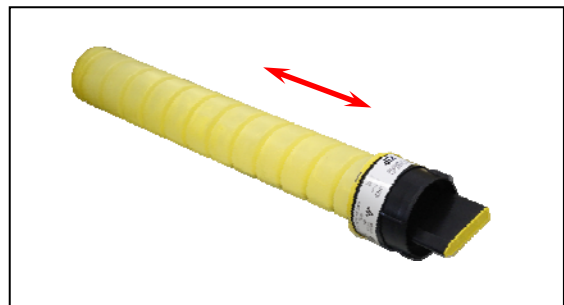

## **!** NOTE

Always use a new Toner Cartridge for replacement. Using an unfinished one would cause an incorrect estimation of the remaining amount of toner in the machine.

4. Hold the Toner Cartridge with the Supply Hole upward. Turn the body part 180 degrees to unlock the Supply Hole.

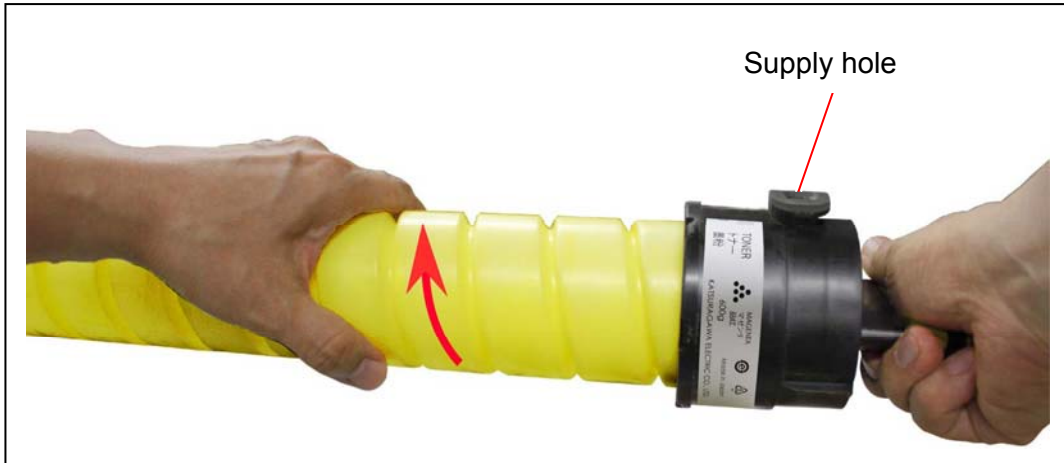

5. Keeping the Supply Hole upward, insert the Toner Cartridge to the corresponding color slot until it stops.

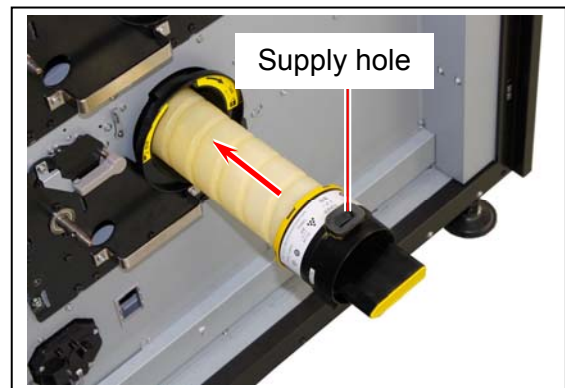

6. Rotate the Toner Cartridge to the arrow direction until it stops.

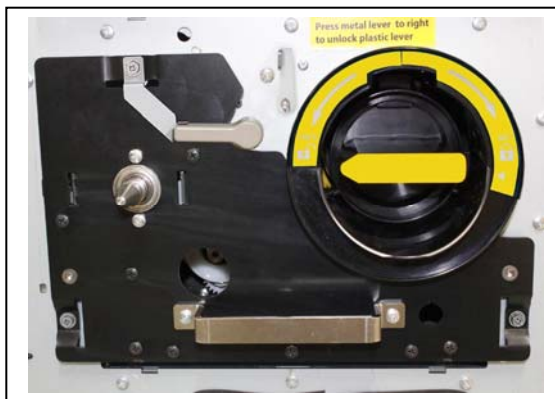

**NOTE**

If unlocking on step 4 is skipped, the UI screen shows “Toner Empty” again in about 10 minutes.

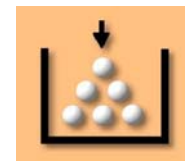

7. Close the Left Side Door.  
Then the toner supply automatically starts.



**⚠ NOTE**

After the Left Side Door is closed;

- (1) The machine goes into “warm up” while processing toner supply.
- (2) The machine will get “ready” when the toner is refilled in the machine.  
(in about 5 minutes)

## 2. 6 Replacing the Waste Toner Box

### ! NOTE

Replace the 2 Waste Toner Boxes “on the rear corner of the machine frame” and “on the Rear Door (for Belt Unit)”.

1. Follow the figure below to assemble 2 Waste Toner Boxes in the “Waste Toner Box Kit”.

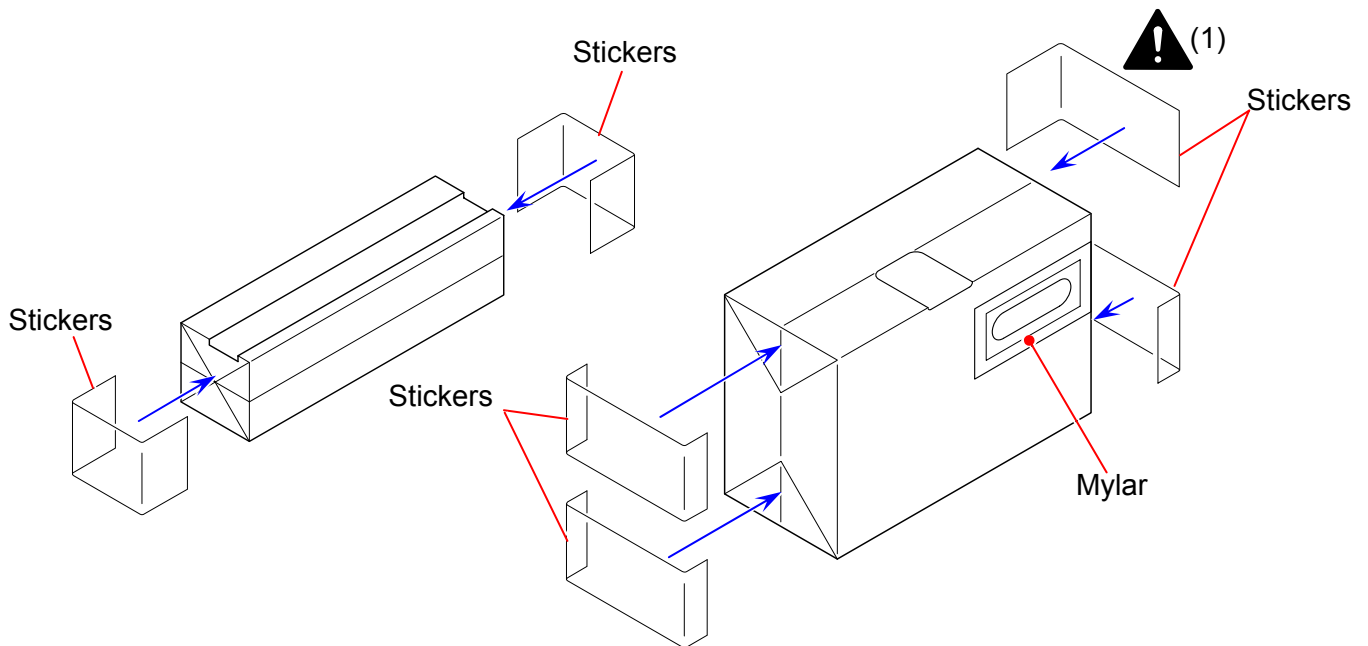

### ! NOTE

- (1) Never overlap the “Mylar” on the sensor window and the “Sticker” on the corner near the window.

Apply the Sticker on the mentioned corner in L shape to avoid the window.

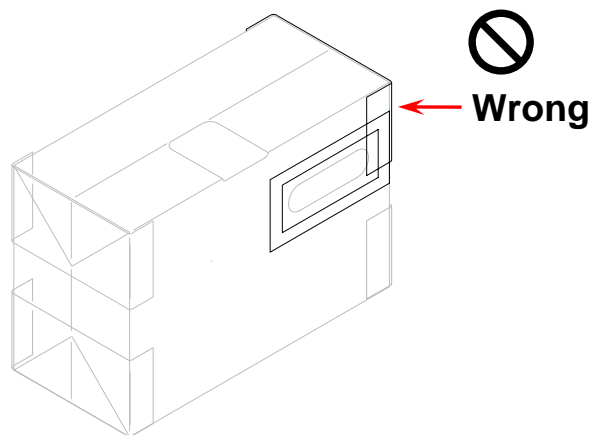

- (2) The kit includes seven sheets of the Stickers. The last one is to seal the box in the future replacement. Keep it in the Waste Toner Case in the later step.

2. Open the Waster Toner Case on the rear right. (bottom left on back side)

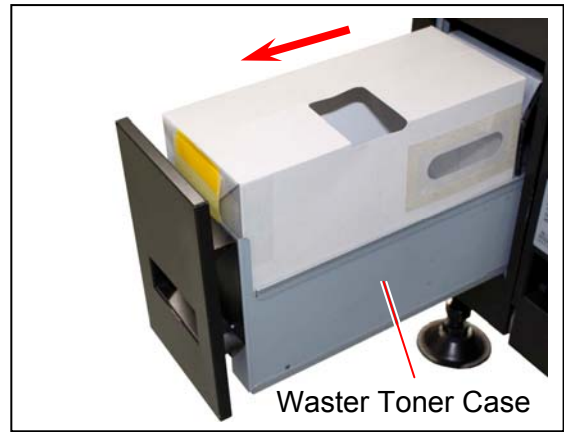

3. Seal the open hole on the top of the using Waste Toner Box with the stored "Sticker".  
Discard the Waste Toner Box according to your local regulations.

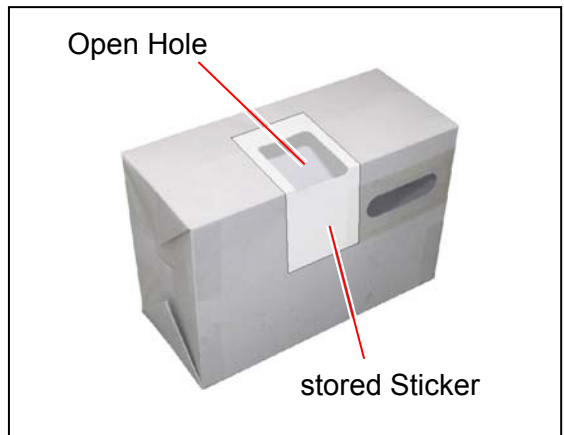
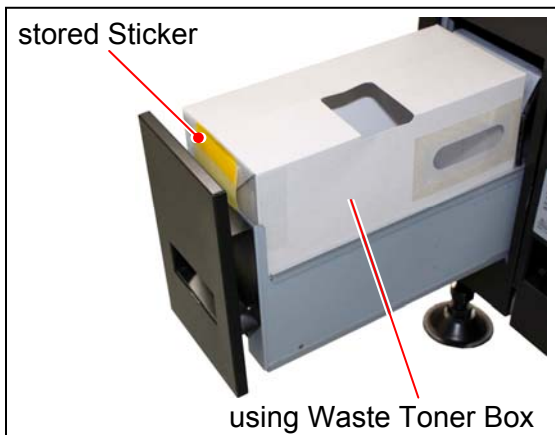

**! NOTE**

- (1) Do not handle the Waste Toner Box roughly. Otherwise the toner will come out from its open hole.
- (2) The Waste Toner Box should be returned to your service technician or should be discarded according to your local regulations.

**! WARNING**

Do not discard it as a flammable. Toner will explode if thrown into the fire. Please ask the seller for the way of dispose.

4. Install the new Waste Toner Box so that the sensor window comes to the machine's center side.

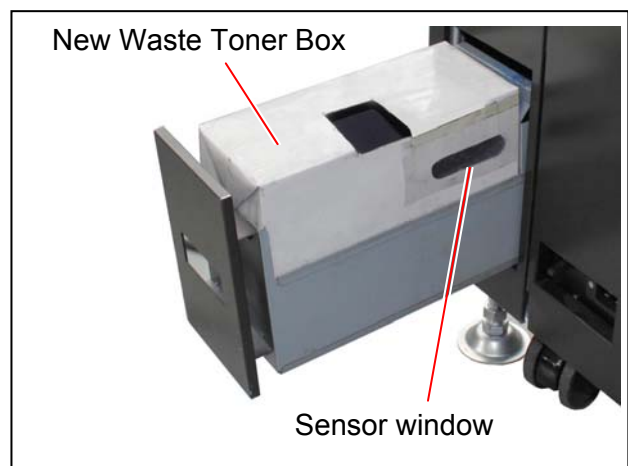

5. Insert the last one sticker in the kit (for future sealing) beside the new Waste Toner Box. Firmly push and close the Waste Toner Case.

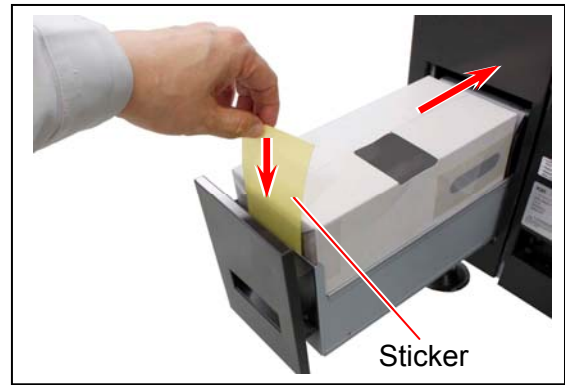

6. Open the Rear Door (Belt Unit).

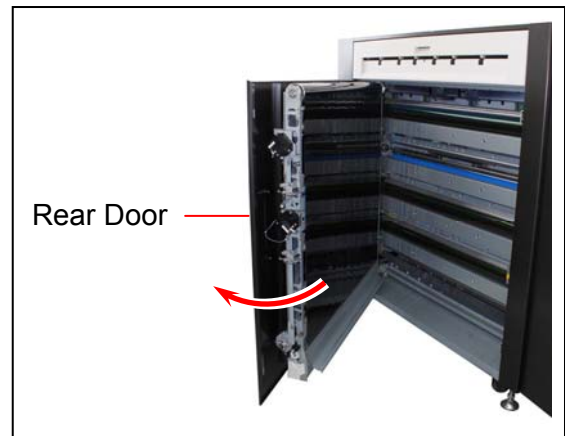

7. Slightly press the Waste Toner Box at the bottom of the Rear Door (Belt Unit).

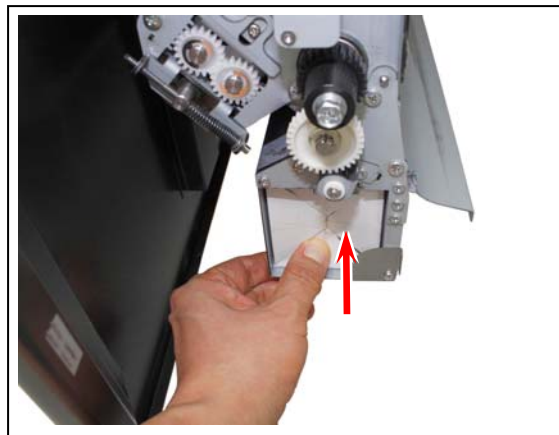
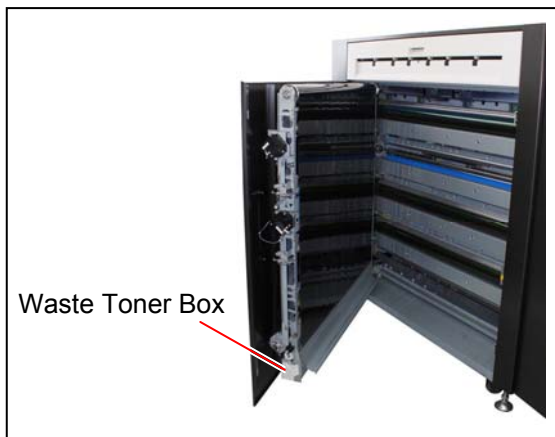

8. With pressing, turn the stopper to the arrow direction to release the Waste Toner Box. Keep it pressing even after releasing.

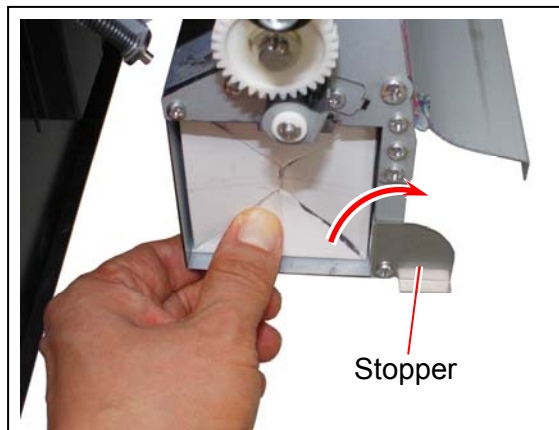

9. Slowly release the pressure. The Waste Toner Box will be pushed toward you. Slowly and gently remove the Waste Toner Box from the machine. Please put the used Waste Toner Box in a plastic bag included to the Waste Toner Box Kit.

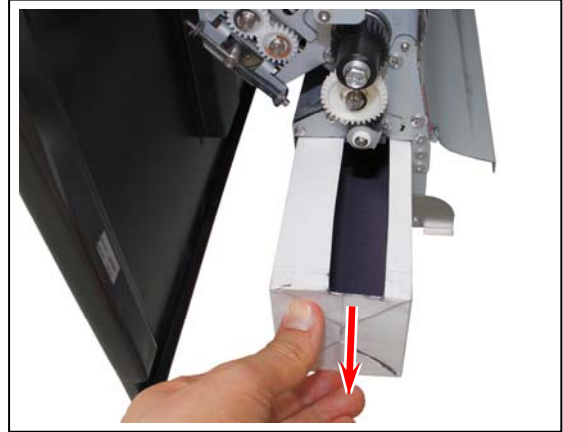

**⚠ NOTE**

- (1) Do not handle the Waste Toner Box roughly. Otherwise the toner will come out from its open hole.
- (2) The Waste Toner Box should be returned to your service technician or should be discarded according to your local regulations.

**⚠ WARNING**

Do not discard it as a flammable. Toner will explode if thrown into the fire. Please ask the seller for the way of dispose.

10. Firmly push and install the new Waste Toner Box (for Belt Unit), and then turn the Stopper to lock it.

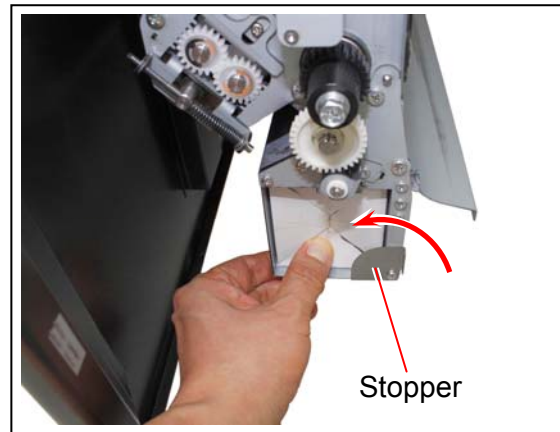
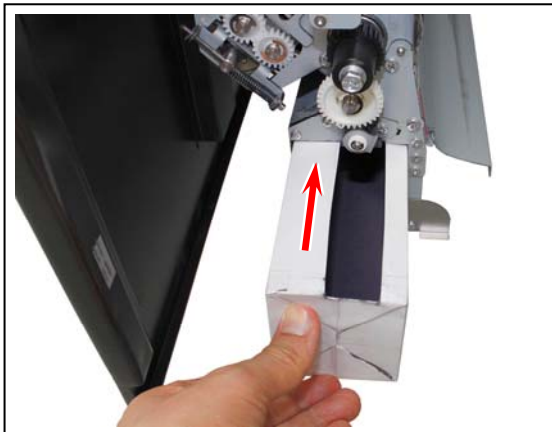

## 2.7 Initial Cut (Straighten the leading edge of roll media)

A new roll media tends to have a rough or folded leading edge. Initial Cut will easily straighten the leading edge by cutting off such poor quality part of the media automatically.

Pressing the Initial Cut Button cuts off the leading edge of the roll media in 120mm.

### NOTE

Some roll media are taped at its leading edge. Even if you remove the tape, glue may remain on the leading edge. This would mess or damage the media path. Before using such a roll media, cut off some amount of the leading edge using a cutter knife and discard the portion with glue.

1. Draw out the concerned Roll Deck fully.

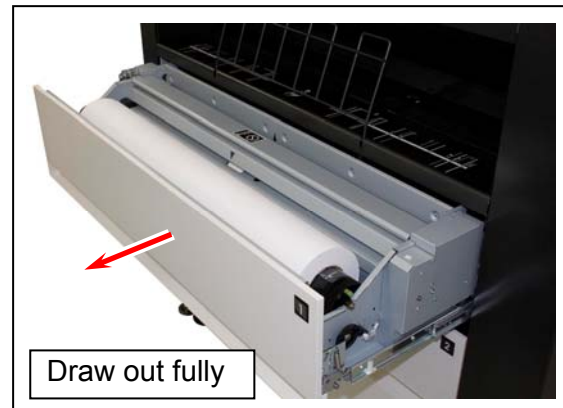

2. Insert the leading edge between the feeding rollers. It will automatically go into the roll media's standby position. (Auto Media Loading)

If the roll media has been set to standby position, go to the next step.

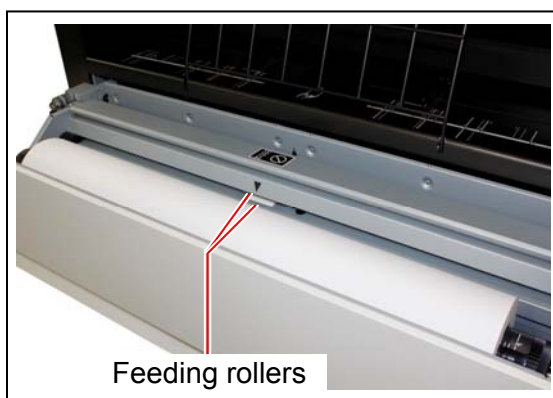

### NOTE

Auto Media Loading will pause unless "Door Open Error" (such as Bypass Feeder, Left Side Door, Rear Door or Paper Exit Door) or a mis-feed media is removed at all.

3. Make sure of the followings prior to an initial cut.
  - The Roll Deck drawer which you want an initial cut is fully opened
  - The upper Roll Deck drawer are firmly closed

**! NOTE**

For Roll Deck 2 and 3, the upper drawer should be closed. If it is open, the leading edge would have an initial cut improperly by touching its bottom.

4. Press the Initial Cut button.  
The leading edge automatically proceeds and has a cut off. The portion will be ejected upward.



5. Remove the portion. Close the Roll Deck.



## 2.8 Sleep Mode

---

The KIP c7800 has two Sleep Modes to reduce the power consumption. The KIP c7800 will enter Sleep Mode after a certain period of inactivity.

In the default setting;

- Warm Sleep Mode will start after a 15 minute of inactivity in order to reduce the power supply for Fuser Unit.
- Cold Sleep Mode will start after a 60 minute of inactivity to stop the power supply for Fuser Unit and some other components.

You can set the period to 240 minutes for example. See further information on Touchscreen Configuration.

Sleep Mode is canceled and the machine gets ready when;

- the machine receives a print job through the network.
- you tap on the UI screen.



### **NOTE**

- (1) It may take time for the machine to get ready.
- (2) Recommended Default Delay Times for Cold Sleep: 60min

# Chapter 3

## Troubleshooting

	Page
<b>3.1 Mis-feed Errors</b> .....	3-2
3.1.1 How to Remove Mis-fed Media .....	3-3
<b>3.2 Open Errors</b> .....	3-11
3.2.1 Roll Deck 1 Open .....	3-11
3.2.2 Roll Deck 2 Open .....	3-11
3.2.3 Roll Deck 3 Open .....	3-12
3.2.4 Roll Deck 1 - Cutter Cover Open .....	3-12
3.2.5 Roll Deck 2 - Cutter Cover Open .....	3-13
3.2.6 Roll Deck 3 - Cutter Cover Open .....	3-13
3.2.7 Sheet Bypass Open .....	3-14
3.2.8 Left Door Open .....	3-14
3.2.9 Rear Door Open .....	3-15
3.2.10 Fuser Exit Door Open .....	3-15
<b>3.3 Other Operator Call Error</b> .....	3-16
3.3.1 Printer out of paper .....	3-16
3.3.2 Printer out of toner .....	3-16
3.3.3 Printer waste toner bottle full .....	3-17
3.3.4 Web Cleaner Empty .....	3-18
<b>3.4 Service Call Errors</b> .....	3-19

# 3. 1 Mis-feed Error

If a media mis-feed happens, the UI screen shows any of the following 4 figures that indicates where a mis-feed has been detected.

The figure would indicate only a “primary” mis-feed location. For a mis-feed while processing multiple sheets, there would be another mis-feed location(s) than the UI indication.

This section instructs you to check for a mis-fed media in the entire media path from the exit to the entrance regardless of the UI indication.

## NOTE

(1) Follow the instruction on the next page, starting with “open the Rear Door.”

(2) While a mis-feed happens, **avoid** doing the followings.

Doing so may damage the surface of the Drum.

- Rewind a roll media before you open Rear Door
- Open a Roll Deck before you open Rear Door

To avoid these, as mentioned in the instruction on the next page, it is very important to open the Rear Door first when a mis-feed happens.

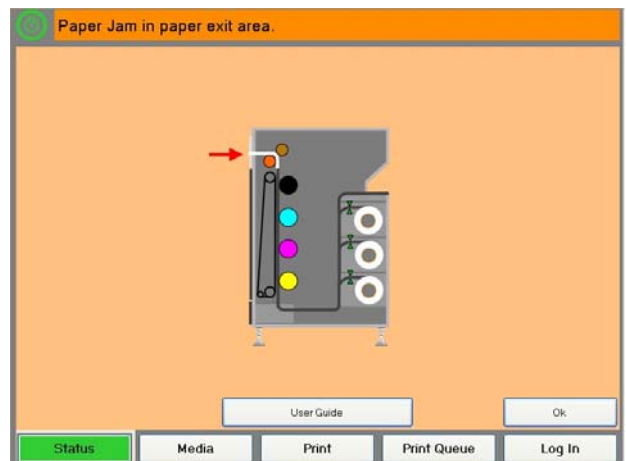
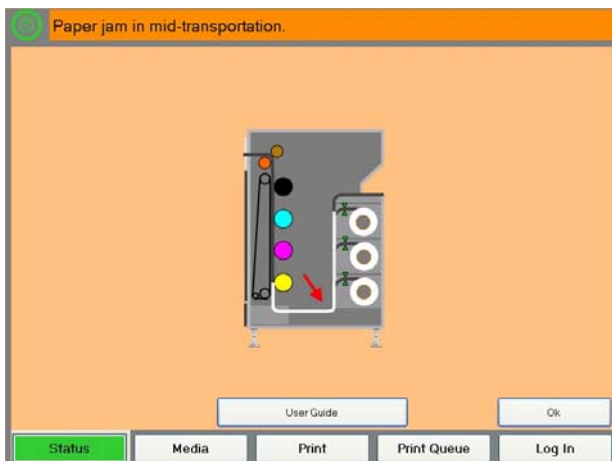
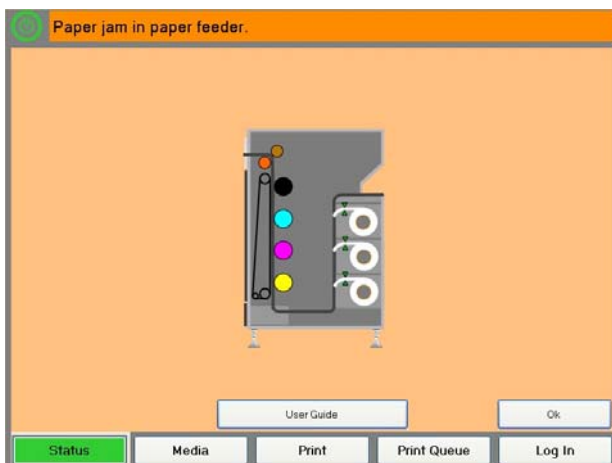

### 3. 1. 1 How to Remove Mis-fed Media

Remove the mis-fed media as instructed in below.

1. Open Rear Door, Fuser Exit Door and Left Side Door.

#### NOTE

Slowly open the Rear Door. The mis-fed media sticks to the Belt surface.

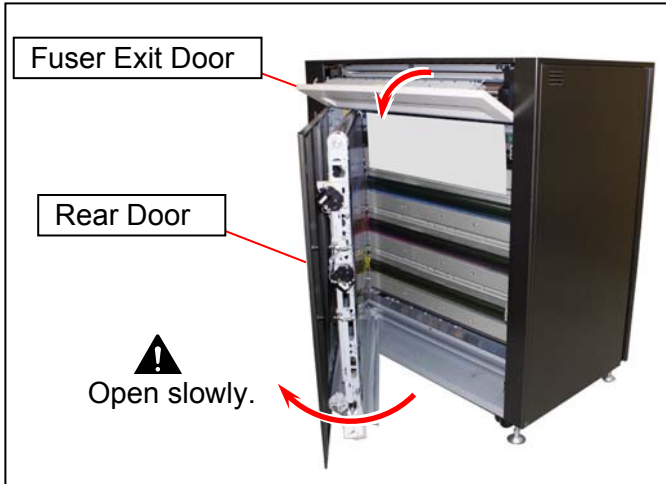

2. If the mis-fed media is being caught in the 2 rollers in the Fuser Unit, turn the green handle on the top of the left side to the arrow direction (clockwise). This will manually forward the media, then pull and remove it.

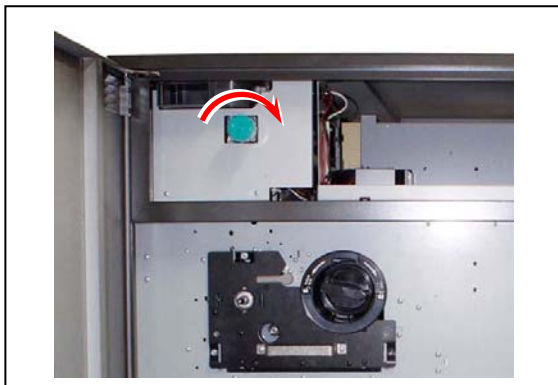

If the mis-fed media is not caught in the Fuser Unit, gently pull it downward

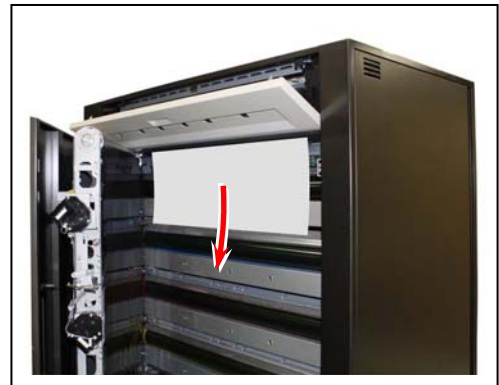

#### CAUTION

Inside of the covers of the Fuser Region is extremely hot, and the mis-fed media is also hot. Take great care not to be burnt when removing the mis-fed media.

3. Remove a mis-fed media in Lower Feeder region by the instruction 3-1 and 3-2.

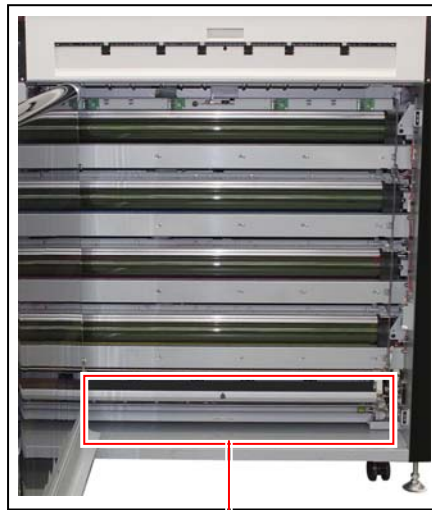

Lower Feeder Unit

3-1 Open the Bypass Feeder, Roll Deck 1, Roll Deck 2 and Roll Deck 3.

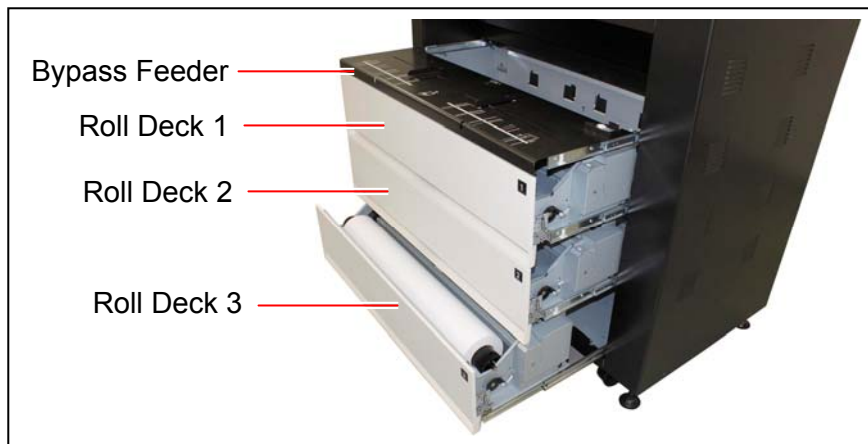

**NOTE**

- (1) If any of Roll Decks is closed, the Roll Deck would catch the media and keep it from being pulled out.
- (2) Opening the Bypass Feeder is not mandatory only for a mis-feed at the Lower Feeder region, but please open it at this point of time for later operation.

3-2. Press the green lever and lift up the upper part of the Lower Feeder Unit.  
While lifting, pull and remove a mis-fed media from the Lower Feeder Unit.

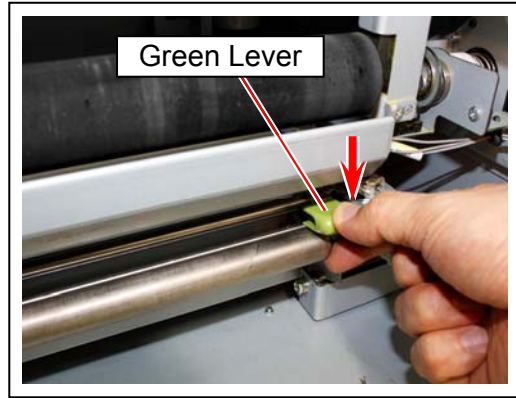

**! NOTE**

If a mis-fed media is found but you could not pull it out, the media have not had cut at the Cutter Unit. It should be cut manually. See [If the mis-fed media not cut yet] on page 3-10.

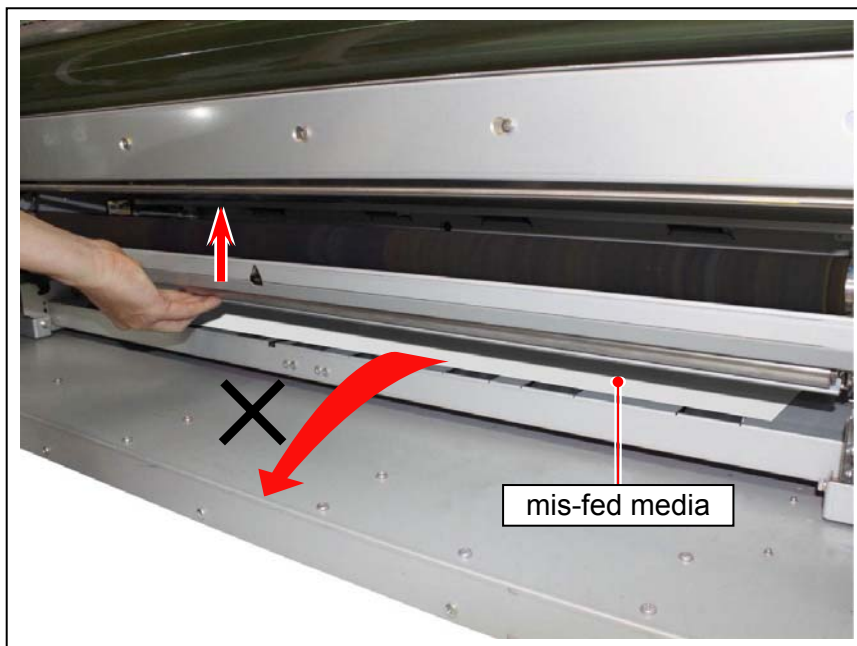

4. Remove a mis-fed media in the front media path.  
Pull and remove it in the back of the deck drawers from the top.  
For a dropped portion inside, close the Bypass Feeder, Roll Deck 1 and Roll Deck 2, and then remove it from the opening between the Roll Deck 2 and 3.

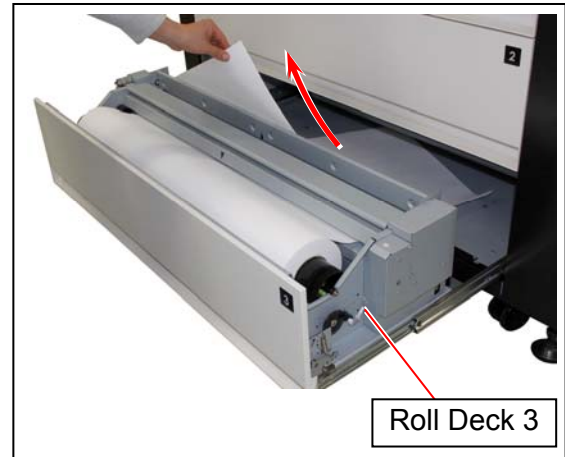

5. Rewind the roll where the mis-fed media came from.

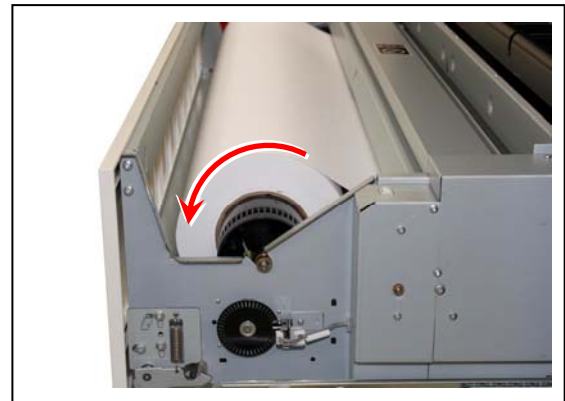

6. Follow the instruction 6-1 through 6-6 to trim the roll's leading edge as needed.

6-1. Close the Bypass Feeder, Left Side Door, Rear Door and Exit Cover.

6-2. Draw out the concerned Roll Deck fully.

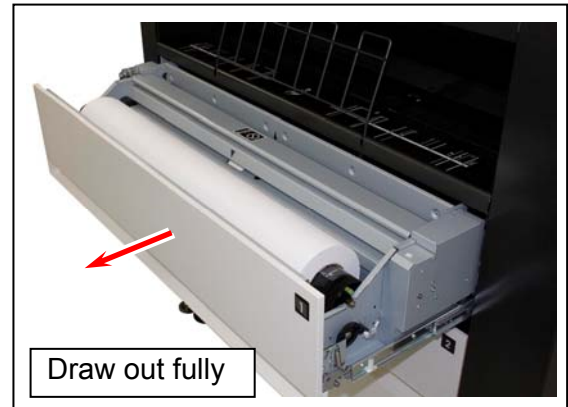

6-3. Insert the leading edge between the feeding rollers. It will automatically go into the roll media's standby position. (Auto Media Loading)

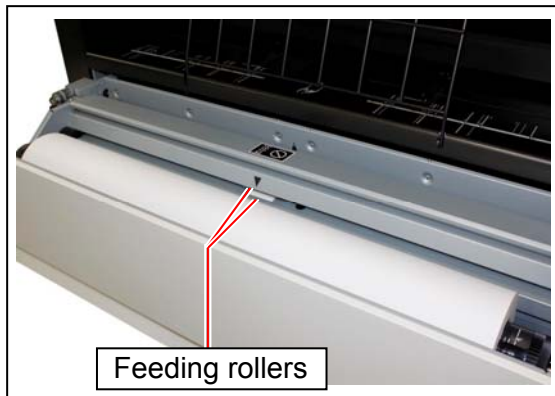

**NOTE**

Auto Media Loading will pause unless "Door Open Error" (such as Bypass Feeder, Left Side Door, Rear Door or Paper Exit Door) or a mis-feed media is removed at all.

- 6-4. Make sure of the followings prior to an initial cut.
- The Roll Deck drawer which you want an initial cut is fully opened
  - The upper Roll Deck drawer are firmly closed

**! NOTE**

For Roll Deck 2 and 3, the upper drawer should be closed. If it is open, the leading edge would have an initial cut improperly by touching its bottom.

- 6-5. Press the Initial Cut button.  
The leading edge automatically proceeds and has a cut off. The portion will be ejected upward.



- 6-6. Remove the portion. Close the Roll Deck.



**Reference**

Details of the Initial Cut is described in [2.7 Initial Cut (Straighten the leading edge of roll media)].

7. This is the end of removing mis-feed media.

**If the mis-fed media not cut yet;**

1. Open the Roll Deck where the mis-fed media comes from. Open the Cutter Cover.

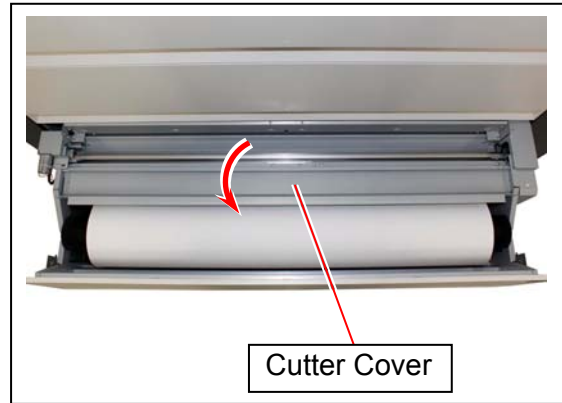
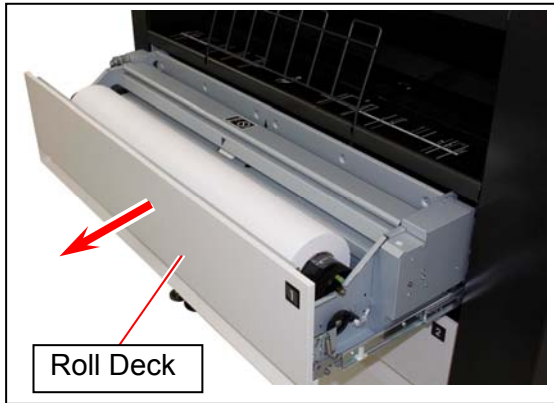

2. Hold the green Cutter Knob. Slide the cutter blade to another end to cut the roll media.  
(This step shows right to left for example)

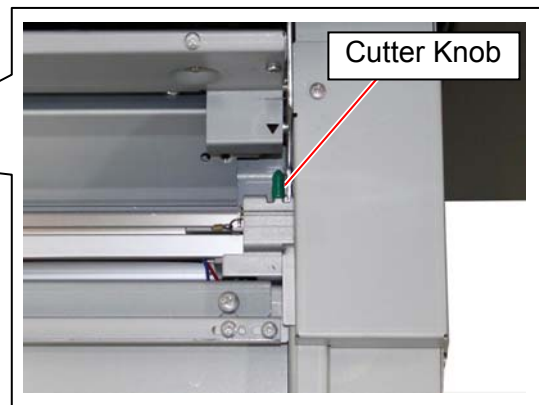
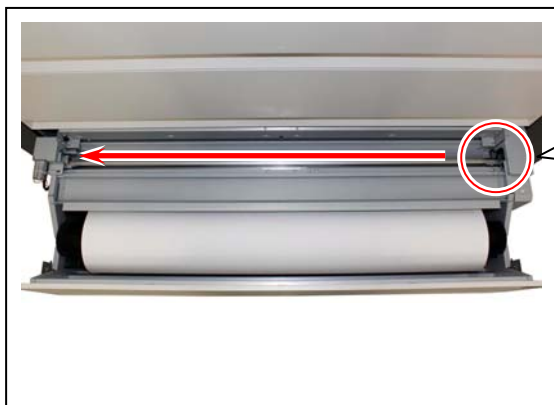

**! NOTE**

Completely slide Cutter Knob until it stops at either end.  
Not doing so may cause a paper jam.

**Reference**

The Cutter Knob seats either end of the deck.  
Sliding right to left may be required as shown  
the right picture.

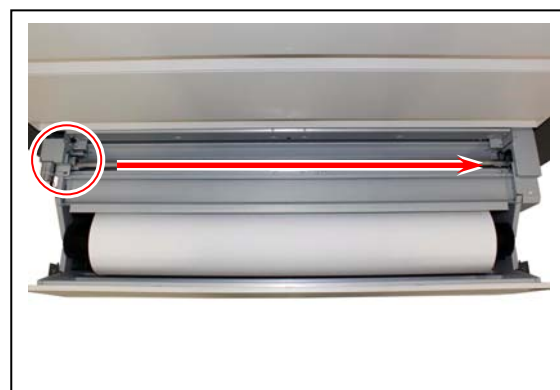

3. Lift up the upper part of the Lower Feeder Unit.  
While lifting, pull and remove a mis-fed media from the Lower Feeder Unit.



4. Close the Roll Decks, Bypass Feeder, Left Side Door, Rear Door and Exit Cover.  
This is the end of removing mis-feed media.

## 3. 2 Open Errors

### 3. 2. 1 Roll Deck 1 Open

“Roll Deck 1 Open” is indicated on the UI Screen when the Roll Deck 1 is opened or not locked completely. Close the Roll Deck 1 firmly to clear the error.

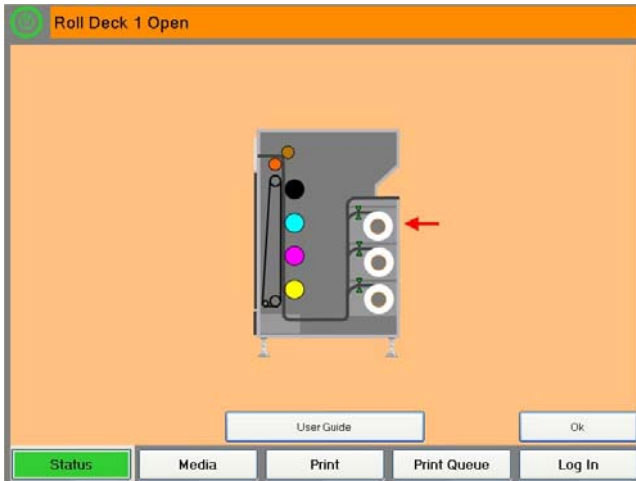

### 3. 2. 2 Roll Deck 2 Open

“Roll Deck 2 Open” is indicated on the UI Screen when the Roll Deck 2 is opened or not locked completely. Close the Roll Deck 1 firmly to clear the error.

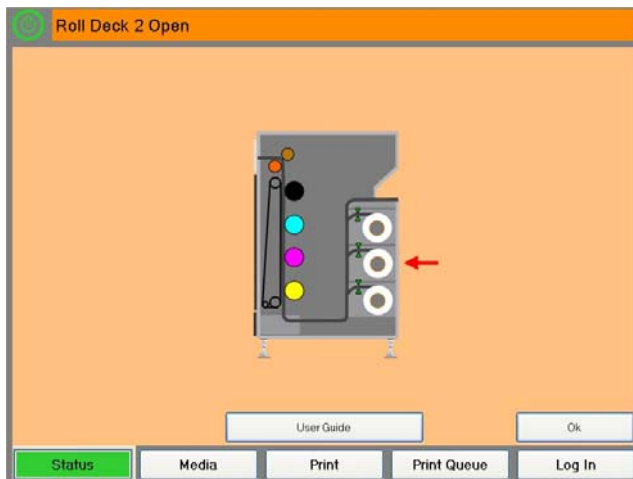

### 3. 2. 3 Roll Deck 3 Open

“Roll Deck 3 Open” is indicated on the UI Screen when the Roll Deck 3 is opened or not locked completely. Close the Roll Deck 1 firmly to clear the error.

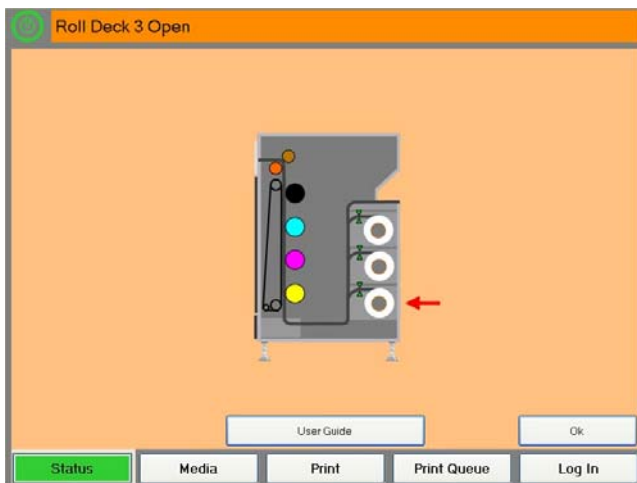

### 3. 2. 4 Roll Deck 1 - Cutter Cover Open

“Roll Deck 1 – Cutter Cover Open” is indicated on the UI Screen when the cutter cover is opened or not locked completely. Close the Cutter Cover firmly to clear the error.

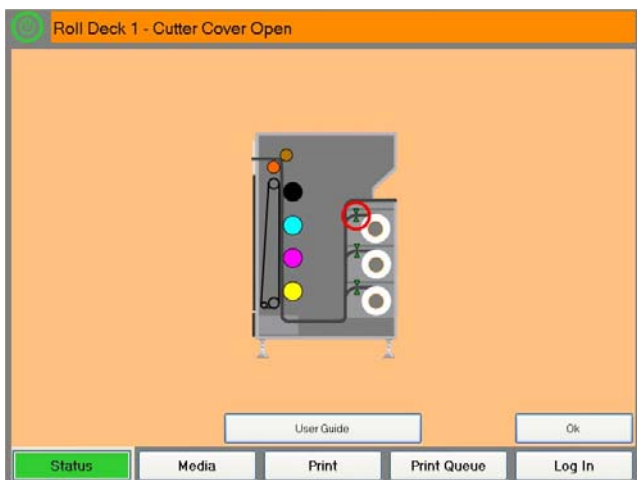

### 3. 2. 5 Roll Deck 2 - Cutter Cover Open

“Roll Deck 2 – Cutter Cover Open” is indicated on the UI Screen when the cutter cover is opened or not locked completely. Close the Cutter Cover firmly to clear the error.

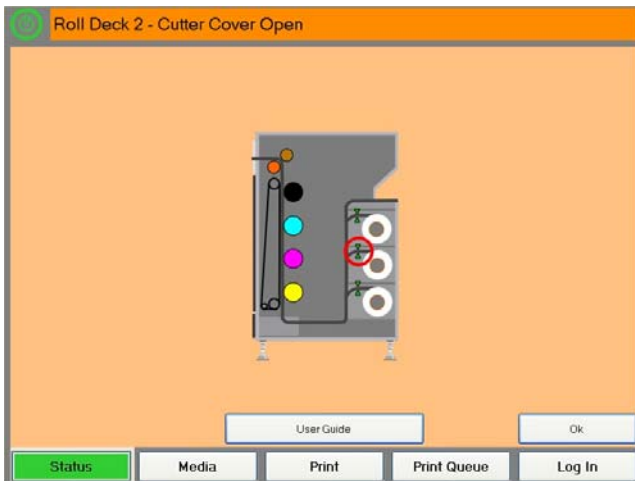

### 3. 2. 6 Roll Deck 3 - Cutter Cover Open

“Roll Deck 3 – Cutter Cover Open” is indicated on the UI Screen when the cutter cover is opened or not locked completely. Close the Cutter Cover firmly to clear the error.

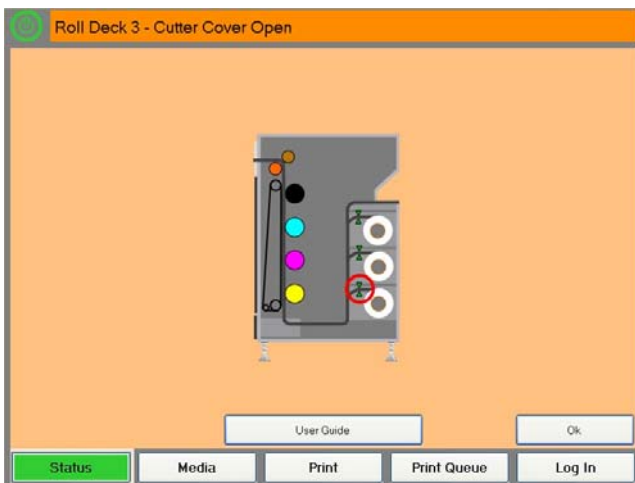

### 3. 2. 7 Sheet Bypass Open

“Sheet Bypass Open” is indicated on the UI Screen when the Bypass Feeder is opened or not locked completely. Close the Bypass Feeder firmly to clear the error.

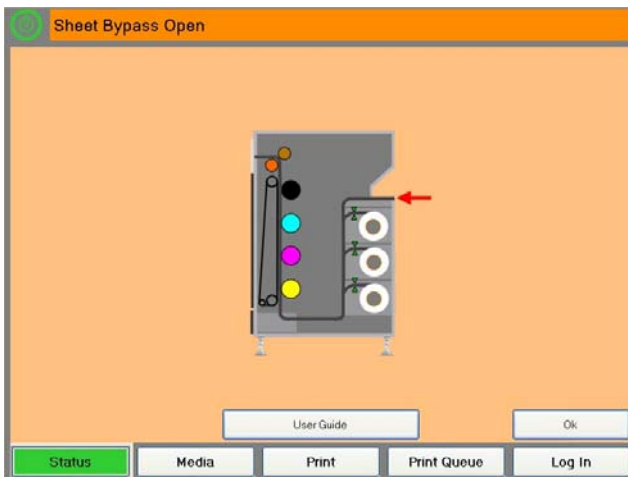

### 3. 2. 8 Left Door Open

“Left Door Open” is indicated when the Left Side Door is opened or not locked completely. Close the Left Side Door firmly to clear the error.

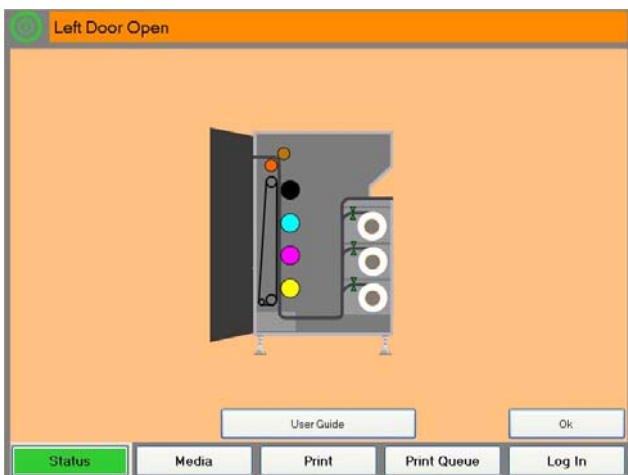

### 3. 2. 9 Rear Door Open

“Rear Door Open” is indicated when the Rear Door is opened or not locked completely. Close the Rear Door firmly to clear the error.

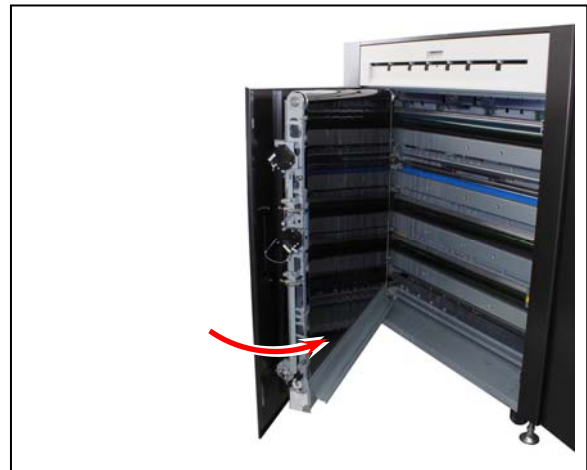
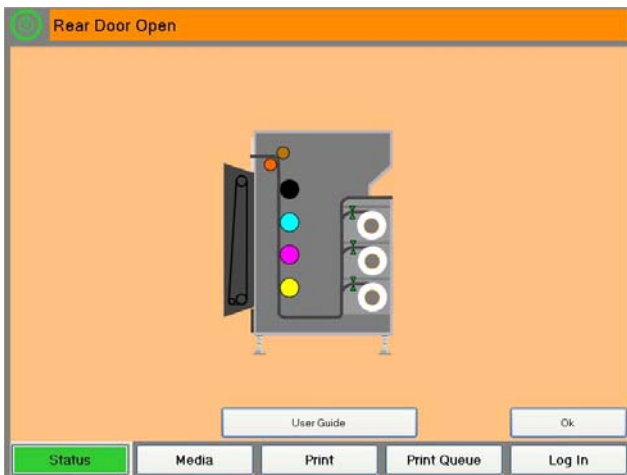

#### ! NOTE

If “Rear Door Open” remains on the UI screen, the Rear Door looks closed but is half-shut. Gently push the circled part of the Rear Door until it clicks.



### 3. 2. 10 Fuser Exit Door Open

“Fuser Exit Door Open” is indicated when the Fuser Exit Door is opened or not locked completely. Close the Fuser Exit Door firmly to clear the error.

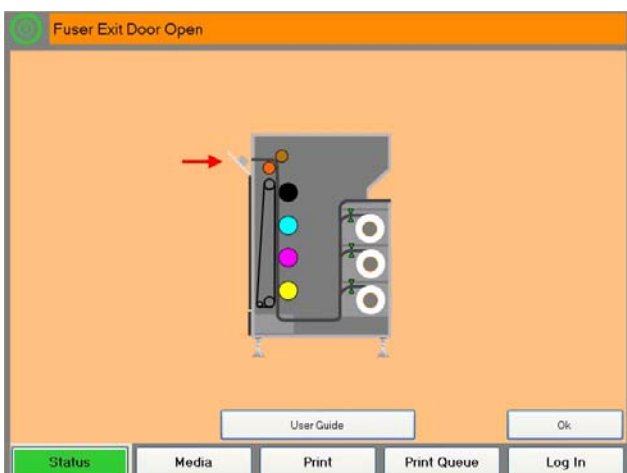

## 3.3 Other Operator Call Error

---

### 3.3.1 Printer out of paper

When a required roll media is emptied, the UI screen shows “Printer out of paper.” For replacement of a roll media, see [2.3 Replacing the Roll Media].

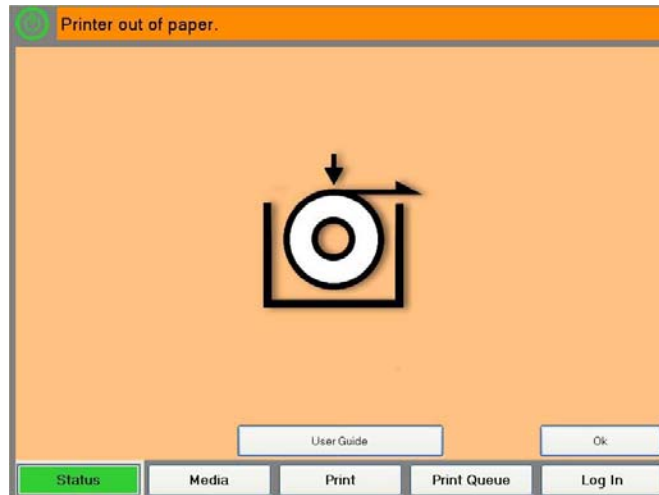

### 3.3.2 Printer out of toner

When any of 4 Toner Cartridges is emptied, the UI screen shows “Printer Out of Toner” and the emptied color name. The printer does not restart operation until the said Toner Cartridge is properly replaced.

For replacement procedure, see [2.5 Replacing Toner Cartridge].

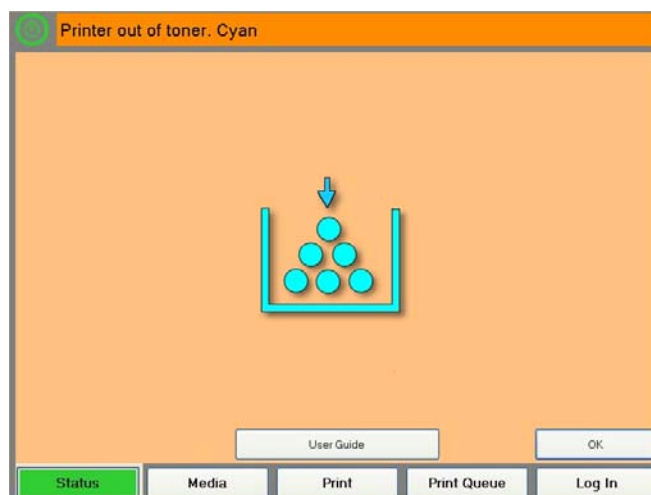

example: Cyan toner emptied

### 3. 3. 3 Printer waste toner bottle full

When the Waste Toner Box is full, the UI screen shows “Printer waste toner bottle full.” The printer does not restart operation until the Waste Toner Box is properly replaced. For replacement procedure, see [2.6 Replacing the Waste Toner Box].

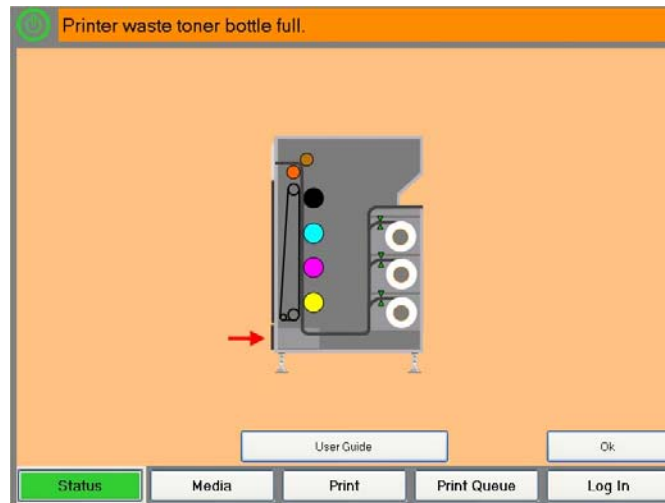

#### **NOTE**

- (1) “Printer waste toner bottle full” also appears if the Waste Toner Box is incorrectly set.
- (2) The printer has 2 Waste Toner Boxes, one is for the Drum (on the rear corner) and the other is for Belt Unit (on the Rear Door).



For Drum



For Belt Unit

### 3. 3. 4 Web Cleaner Empty

Web Cleaner is a component to clean Fuser Unit.

When the remaining Web Cleaner is low, the UI screen displays “Web Near End”. (The KIP C7800 is still available)

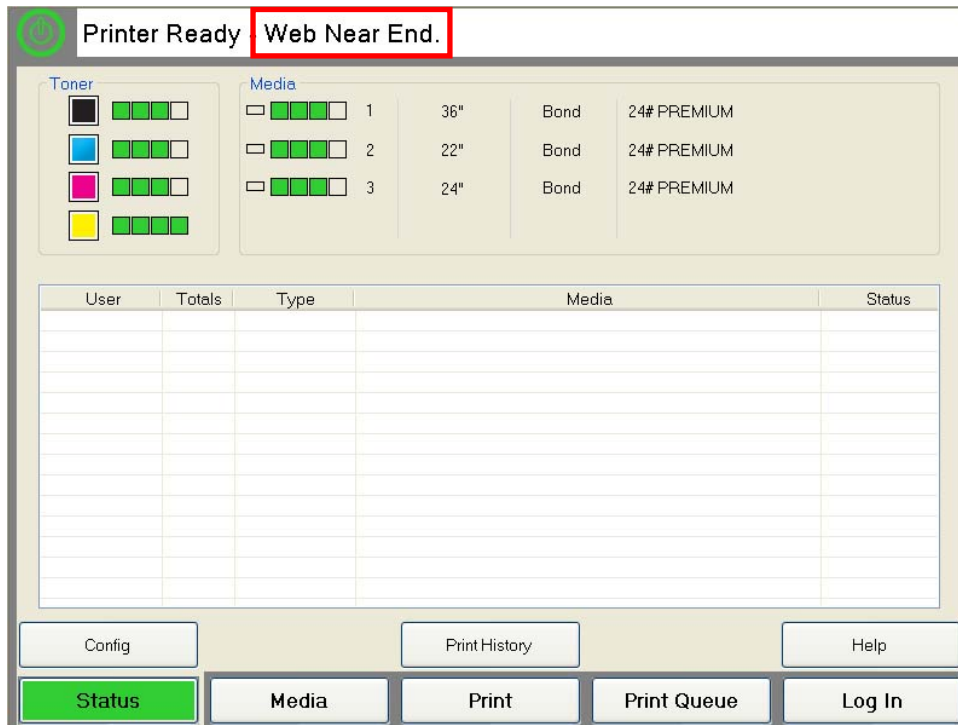

“Out of Web” error will appear over a period of time, and the KIP C7800 becomes unavailable. Please call your service representative to replace Web Cleaner early.

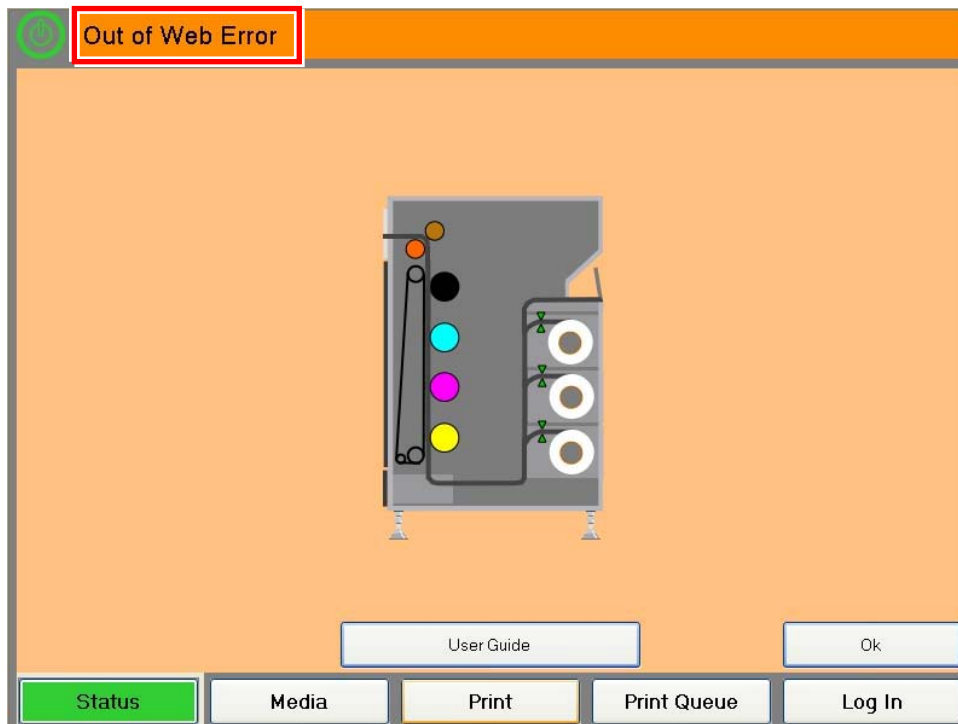

#### **NOTE**

Web Cleaner can be replaced by a well trained technician only.

## 3. 4 Service Call Error

---

If an error with significant effect on the printer occurs, the printer stops the operation and indicates a related Customer Engineer Call Error Code (or description, and its equivalent internal code) on the UI screen.

Call the service staff immediately as these problems can be fixed by a well trained technician only.

Before calling the service staff, try to turn on/off the KIP C7800. If “Service Call Error” is indicated again, turn off the machine, unplug it, and call the service staff with reporting the error description in the UI screen.

CE-Call Error (Service Call Error)

- Sensor Error
- Motor Error
- Cutter Error
- Fan Error
- Fusing Temperature Error
- LED Head Error
- High Voltage Power Supply Error
- Density Control Error
- Belt Skew Error
- Memory Error

A corresponding description will be displayed in the top column (status region) in the UI screen. For example, “Belt Skew Error (left side)”

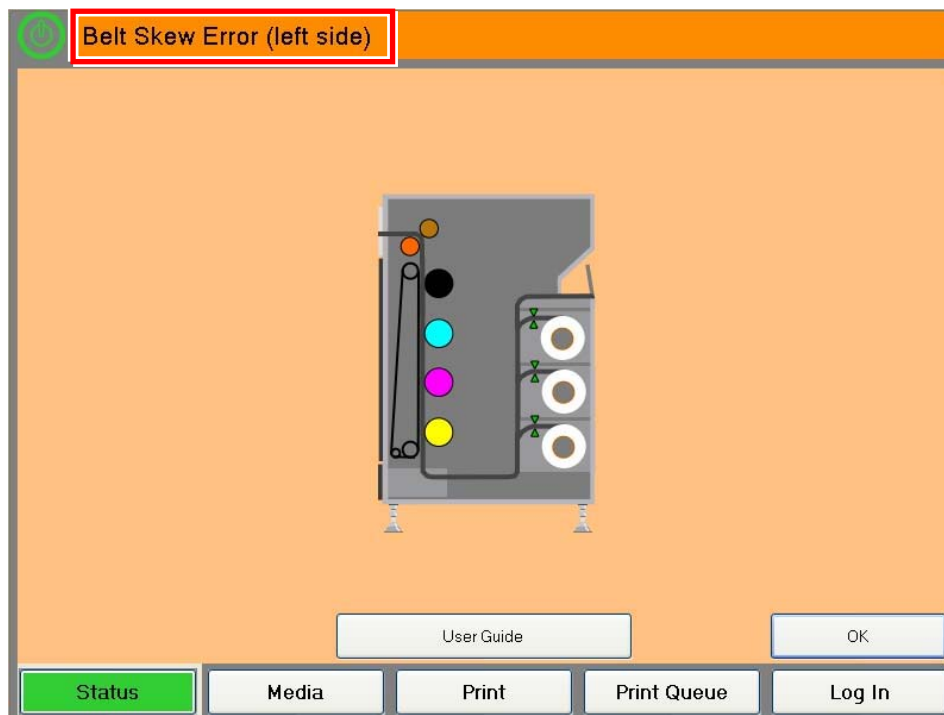



U.S.A. ■ Phone: (800) 252-6793 ■ Email: [info@kipamerica.com](mailto:info@kipamerica.com) ■ Website: [www.kip.com](http://www.kip.com)

CANADA ■ Phone: (800) 653-7552 ■ Email: [info@kipcanada.com](mailto:info@kipcanada.com) ■ Website: [www.kip.com](http://www.kip.com)

KIP is a registered trademark of the KIP Group. All other product names mentioned herein are trademarks of their respective companies. All product features and specifications are subject to change without notice. Complete product specifications are available upon request.